

# Weighing Solutions in Bulk Processes

With Innovative Solutions

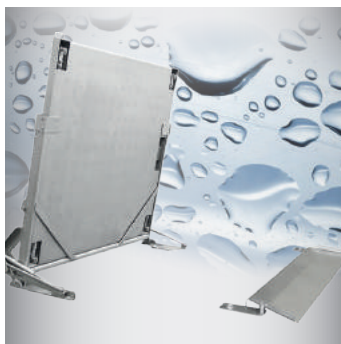

**BAYKON**  
Industrial Weighing Systems

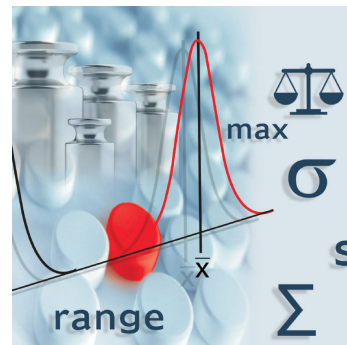

## Sector leader...

BAYKON is one of the leading companies in the Global Industrial Weighing sector with;

- ✓ Wide range of products from basic weighing to advanced weighing solutions,
- ✓ Possessor of international accreditations and sectoral certificates,
- ✓ Trained and experienced professional manpower to support our business partners,
- ✓ Export more than 90 countries with Global experience.

Since 1987, industrial weighing instruments manufacturer BAYKON has built upon its reputation for product quality, international experience, technical innovation, fast and effective customer support.

We deliver weighing products that integrate productivity, compliance, quality and safety into your weighing applications and solutions. Our experienced and well trained team using the most up-to-date technology, develops and manufactures state-of-the-art weighing instruments; our project team, as a solution provider, eliminates customers problems by developing innovative products and customized solutions.

### CONTENTS

Process Instruments .....	1-4
Filling & Packing Controllers .....	5-10
Discontinuous Totalizer .....	11-14
Checkweighers .....	15-16
Packing & Portion Scales .....	17-20
Formulation & Additive Weighing .....	21-24
Tank, Reactor and Silo Scales .....	25-32
Ex-Proof Weighing Systems .....	33-34
BAYKON SQC Statistical Quality Control .....	35-38
Industrial Scales .....	39-42

**BAYKON is a member of CECIP - The European Weighing Industry Association.**



## Innovative Weighing in Process

High accuracy with the highest resolution and very fast speed

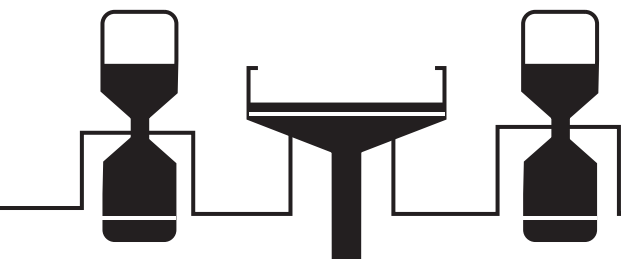

## Process Instruments

# TX16 Analogue Transmitter

The built-in accurate multimeter and very fast speed measurement with Baykon know how.

BAYKON's innovative analogue transmitter TX16 is an economical, high-tech, fast speed and highly accurate weighing instrument for Process Weighing Systems. Its display indicates the analogue output value always in operation.

## Typical Applications

- ✓ Tank and silo weighing
- ✓ Industrial weighing applications
- ✓ Force measurement
- ✓ Pressure measurement
- ✓ Dozing systems
- ✓ Process control

## Easy Usage

- ✓ Easy programming with display and keys,
- ✓ Built-in multimeter eliminates the external voltmeter / amperemeter connection needs.
- ✓ Stable reading for agitation tanks and vibrating environments,
- ✓ Bidirectional load cell signal inputs and analogue output for force measurements
- ✓ Easy adjustment of high-capacity tanks and silos with eCal, electronic adjustment feature,
- ✓ USB port for PC connection.

## Built-in Multimeter

The analog output value is always shown on the display with very high accuracy. This feature eliminates the need for an external measurement instrument connection in operation or in service.

## Alphanumeric Display and Keys

- ✓ Easy programming and accurate adjustment,
- ✓ Analogue output value is always shown on the display,
- ✓ Announces the system malfunctions on the display to find solution fast.

## Analogue Output

- ✓ Galvanically isolated analogue output ;  
0-20mA , 4-20mA, 0-10VDC,  $\pm 10$ VDC, 0-5VDC or  $\pm 5$ VDC
- ✓ Up to 60000 steps of analogue output resolution
- ✓ Stable output with adjustable adaptive filter,

## A Very High Resolution for Fast and Accurate Measurement

One billion internal resolution and very high conversion rate, up to 1600 conv. per second. A very fast measurement provides high accuracy with adaptive filtering. Precise pre-adjustment and matching of the TX16s during production ensures a very high electronic setting accuracy.

## Very High Reliability

- ✓ Triple signal isolation ensures high reliability.
- ✓ Very high EMC immunity,
- ✓ EMC protection in interfaces
- ✓ Error output warns the operator of system malfunctions.

## Digital Inputs/Outputs

- ✓ Galvanically isolated 3 digital inputs / 4 digital outputs
- ✓ 3 outputs for cut-out values,
- ✓ Digital input for zeroing
- ✓ Error output



# TX20 State of the Art Digital Transmitter

## Very high accuracy and fast speed with an extremely high resolution.

TX20 series digital transmitters are designed to provide efficiency and accuracy at force, moment, and pressure measurement in addition to static and dynamic weighing applications. Its alphanumeric display ensures easy usage and programming. Logging feature of TX20 helps users traceability of the system.

### Typical Applications

- ✓ Tank and silo weighing
- ✓ Industrial applications
- ✓ Force measurement
- ✓ Pressure measurement
- ✓ Process control
- ✓ Dozing systems

### Easy Usage

- ✓ Easy programming with display and keys,
- ✓ Stable reading for agitation tanks and vibrating environments,
- ✓ Bidirectional load cell signal inputs for force measurements
- ✓ Easy adjustment of high-capacity tanks and silos with a precise eCal adjustment
- ✓ PC connection via USB.
- ✓ 1 000 000 external resolutions for adjustment in PLC allowing easy start up and service. Changing the instrument do not require readjustment.

### Wide Range Interface

- ✓ Modbus RTU (via RS485) and Modbus TCP protocols
- ✓ Industrial Ethernet variants with dual ports for daisy chain connection
- ✓ Galvanically isolated 3 digital inputs / 4 digital outputs
- ✓ Isolated analog output 0-20mA , 4-20mA, 0-10VDC, ±10VDC...
- ✓ USB port
- ✓ Profinet S2 System Redundancy

### Very High Reliability

- ✓ Triple signal isolation ensures high reliability.
- ✓ Very high EMC immunity,
- ✓ EMC protection on interface lines
- ✓ Error output warns the operator at system malfunctions.
- ✓ Logging of the weighing system interventions and failures helps the user with the traceability of the system.

### Alphanumeric Display and Keys

- ✓ Easy programming and accurate adjustment with a product special alphanumeric display,
- ✓ Measured value is always shown on the display,
- ✓ Announces the system malfunctions on the display to find solution easily,

### A Very High Resolution for Fast and Accurate Measurement

One billion internal resolution and very high conversion rate, up to 1600 conv. per second. A very fast measurement provides high accuracy with adaptive filtering. Precise pre-adjustment and matching instruments in production allows a very high electronic adjustment accuracy.

### Digital Inputs/Outputs

- ✓ Galvanically isolated Digital 3 inputs and 4 outputs
- ✓ Outputs for cut-out values,
- ✓ Error output,
- ✓ Zeroing, Taring etc. inputs

### Remote Inputs/Outputs

- ✓ Digital inputs and outputs of TX20 can be used as a Remote I/O of the PLC to minimize additional instruments at the weighing system.

### Interface Variants :

- RS-485
- Analogue output
- Ethernet TCP/IP (2 Ports)
- Profinet S2 (2 Ports)
- EtherCAT (2 Ports)
- Digital I/O
- Modbus RTU / TCP
- Profinet (2 Ports)
- EtherNet/IP (2 Ports)
- Powerlink (2 Ports)



# Innovative Process Weighing Indicators

## High accuracy and high speed at process weighing with BAYKON technology and know-how

Baykon process weighing indicators are high-tech, economical, and smart instruments. With their advanced and intelligent electronics, Baykon meets all your requirements, from basic to the most complex industrial weighing applications.



**BX10 / BX11**

- Approved for EU NAWI , weighing in trade applications.
- 14 mm height 6 digits display with annunciators.
- For industrial weighing / force / pressure measurements in process applications
- Up to 1600 measurements per second.
- A very high accuracy and stability due to adaptive filtering
- Internal 8 000 000 and external up to 300 000 resolution
- Galvanically isolated digital 4 inputs and 5 outputs.
- Digital I/O's can be programmed as Remote I/O of the PLC.
- 1 000 000 external resolution for adjustment at PLC allows changing the instrument without recalibration.
- All variants have RS232C, RS485 and Modbus TCP/IP interfaces.
- Wide range of interface variants ; Profibus, Profinet, Modbus RTU, Modbus TCP, EtherNet/IP, EtherCAT, Powerlink, CANopen, CC link and Profinet S2 for redundant systems.
- BX11 Panel size is 55x100 and the depth is 99 mm.



**BX30 / BX30D**

- BX30 is used with analogue load cells and BX30D is developed for digital load cells.
- Approved for EU NAWI, weighing in trade applications.
- For industrial weighing / force / pressure measurements in process applications.
- Up to 1600 measurements per second.
- A very high accuracy and stability due to adaptive filtering
- Internal 8 000 000 and external up to 300 000 resolution
- Galvanically isolated digital 4 inputs and 5 outputs.
- Digital I/O's can be programmed as Remote I/O of the PLC.
- All variants have RS232C, RS485 with Modbus RTU, Ethernet TCP/IP with Modbus TCP, and USB interfaces.
- Wide range of interface variants ; Profibus, Profinet, Modbus RTU, Modbus TCP, EtherNet/IP, EtherCAT, Powerlink, CANopen, CC link and Profinet S2 for redundant systems.
- Programmable digital I/O for peripheral control points like vibration, air pressure switch, outlet is full etc.
- Panel size is 108x205 and the depth is 112.5 mm.
- BX30Plus variants have basic checking and classifying modes additionally.
- Peak hold mode catches up to 10 peak loads in force testing.



# Filling Terminals for all Filling Processes

EU MID Approved  
up to 0.1% accuracy

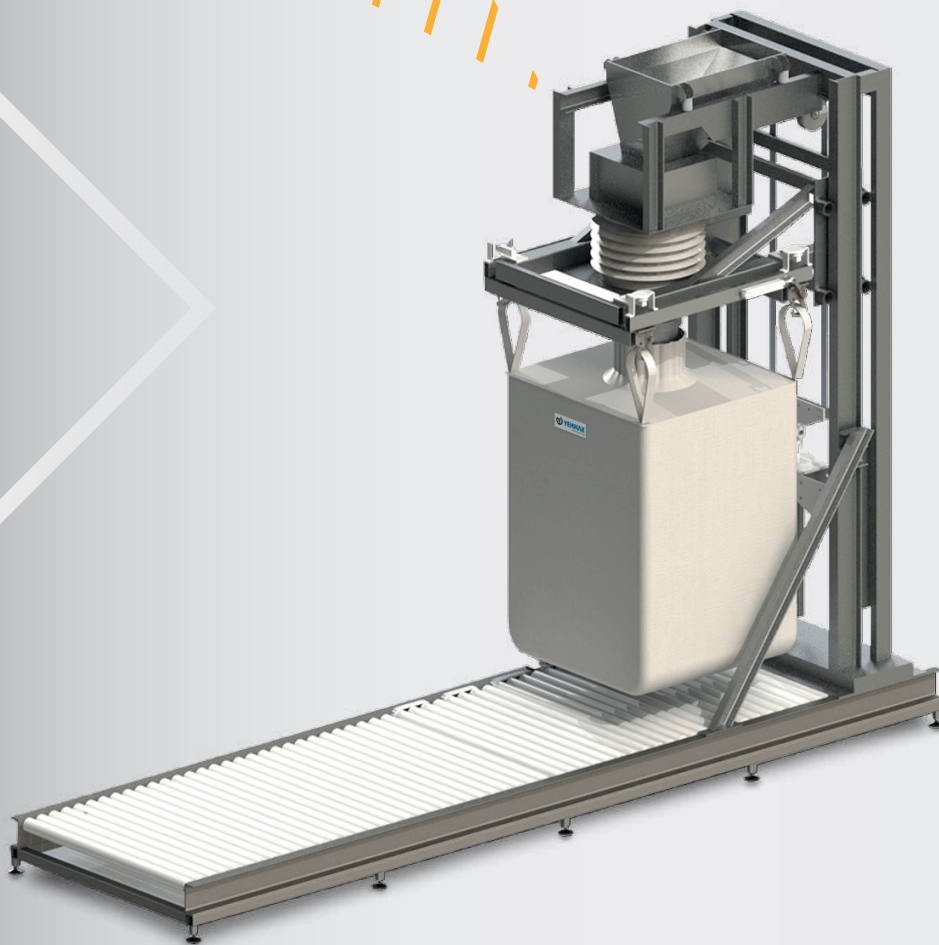

## Filling & Packing Controllers

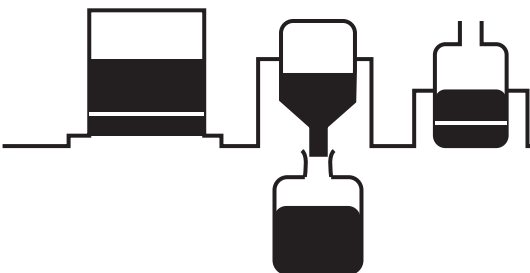

# Filling & Packing Controllers

## High accuracy and high speed at Filling with BAYKON technology and know-how.

Baykon filling and packing controllers are high tech, smart and economic instruments. Their filling modes fit to control the most common gravimetric filling machines. With their advanced and intelligent electronic technologies, Baykon filling controllers meet all your requirements, from basic to the most complex filling machine applications. Integration of Baykon controllers to the factory automation system - like SCADA, PLC , PC etc - is very simple!



**BX13**

- Approved for EU MID and OIML R61, Ref class 0.2.
- Single range weight indication up to 300 000 division.
- Up to 1600 measurements per second.
- Filling control accuracy is 10 times higher than display division.
- 6 different operation modes.
- Easy access to the recipe, target and cut off values.
- Galvanically isolated 4 digital input and 5 digital outputs.
- RS232C and RS485 standard interfaces.
- Wide range Fieldbus interfaces are available: Profibus, Profinet, Modbus RTU, Modbus TCP, EtherNet/IP, EtherCAT, Powerlink, CANopen, CC link, and Profinet S2 for redundant systems.
- Small and compact panel type housing. Its panel cut-out fits 48 x 96 mm standard panel size.



**BX30 Fill**

- Approved for EU MID and OIML R61, Ref class 0.1.
- Single range, multi range and multi interval weight indication up to 300 000 division.
- Up to 1600 measurements per second.
- Filling control accuracy is 1000 times higher than display division.
- 12 different operation modes.
- Configurable recipe content. Easy access to target, cut-off values and receipt with specified keys.
- Galvanically isolated in-house or external 12 digital inputs and 14 digital outputs.
- 250 pcs receipt memory.
- 250 pcs memory for identification data.
- Multipoint level control at drum filling on the palette.
- Programmable digital I/O for peripheral control points like vibration, air pressure switch, outlet is full etc.
- Ethernet, USB, RS232C and RS485 standard interfaces
- Wide range Fieldbus interfaces are available: Profibus are Profibus, Profinet, Modbus RTU, Modbus TCP, EtherNet/IP, EtherCAT, Powerlink, CANopen, CC link and Profinet S2 for redundant systems.





# BX13 - Filling and Packing Controller



## Fast & Accurate filling, easy usage with powerful functions in the software

BX13 is a professional filling controller designed for any type of filling process of liquid, bulk, and granular materials. With its 16 000 000 internal resolutions, high speed conversion up to 1600 measurements per second and selectable digital and statistical filters, BX13 provides very fast and accurate filling results in even harsh environments with vibration.

**Easy Usage**  
Short cut \* Key is used to enter target, coarse and fine cut-off values.

**Fast and Accurate**  
Up to 16000 conv/sec. 16 000 000 internal resolution OIML approval for 0.2% accuracy. High speed real time operation. 10 ms response delay.

**Compact Hardware and Software**  
The embedded filling functions provide easy commissioning.

**Housing & Power**  
IP65 stainless steel front panel  
Stainless steel rear panel  
Aluminium body,  
Panel cut-out size 48 x 96  
Panel depth 100mm  
12 -28 VDC power source

**Standard Interfaces**  
● RS232C  
● RS485

**PLC Interfaces :**  
● Profibus  
● Profinet  
● Profinet S2 redundancy  
● Modbus RTU  
● Modbus TCP  
● EtherNet/IP  
● EtherCAT  
● CANopen  
● CC-Link  
● CC-Link IE  
● Powerlink  
● Digital I/O  
● Ethernet TCP/IP

**Programming and Calibration**  
Calibration with or without test weights. Easy programming via keys. Easy access to process related parameters. Programming and calibration via PC or PLC. Calibration via fieldbus interface. Selection the filling mode defines the machine type automatically.

**Filling Modes**  
✓ Open container filling  
✓ Bung-type Container filling  
✓ Bagging / Packing  
✓ Multicycle Bagging  
✓ Weigh-in / Weigh-out  
✓ Valve type bag filling.



# BX30 Fill - Filling and Packing Controller



## High accuracy at Filling with BAYKON technology and know-how.

BX30 Fill controller is high tech, smart and economic instrument for usage at various filling and packing machines. Its configurable recipe content feature, smart filling algorithm, and availability of master-slave connection gives big advantages in usage.

### SmartAPP

This feature gives the operator an advantage to follow the operation on the display with back light colours and bar graph. Smart adjustment technics and smart start-up are its additional advantages for fast and accurate commissioning and filling.

### Easy Usage

Short cut keys to enter target, coarse and fine cut-off values. Recipe key provides fast recipe changing. Programmable 5 key for your effective usage.

### Fast and Accurate

Up to 1600 conv/sec.  
16 000 000 internal resolution  
OIML approval for 0.1% accuracy.  
High-speed real-time operation.  
response delay from 2 ms.



### Standard Interfaces

- Ethernet TCP/IP
- USB
- 2X RS 232C
- RS 485

### PLC Interfaces :

- Profibus
- Profinet
- Profinet S2 redundancy
- Modbus RTU
- Modbus TCP
- EtherNet/IP
- EtherCAT
- CANopen
- CC-Link
- CC-Link IE
- Powerlink
- Digital I/O
- Ethernet TCP/IP

### Filling Modes

- ✓ Open container filling
- ✓ Bung-Type container filling
- ✓ Filling with lance control
- ✓ Packing
- ✓ Bagging
- ✓ Big bag filling
- ✓ Valve bag filling
- ✓ Bagging machine with one hopper scale
- ✓ Bagging machine with up to 16 scale
- ✓ Packing machine with up to 16 scale
- ✓ Tank filling & filling from tank
- ✓ Weigh-in / weigh-out

### Master –Slave Connection

Master-slave inter connection between BX30 Fill controllers provides;

- ✓ Transferring the set up and recipe data to slave instruments
- ✓ Full control of bagging /packing machines up to 4 weighing hoppers.

### Digital Inputs and Outputs

In-house digital I/O board or DIN rail mount RIO16 digital I/O unit. All I/O's are galvanically isolated and outputs are short circuit protected. The operator is warned in case of any open or short circuit at any output! In case of any digital I/O failure, one of the reserved I/O ports can be swapped with the faulty one to continue the operation until receiving the new digital I/O board.

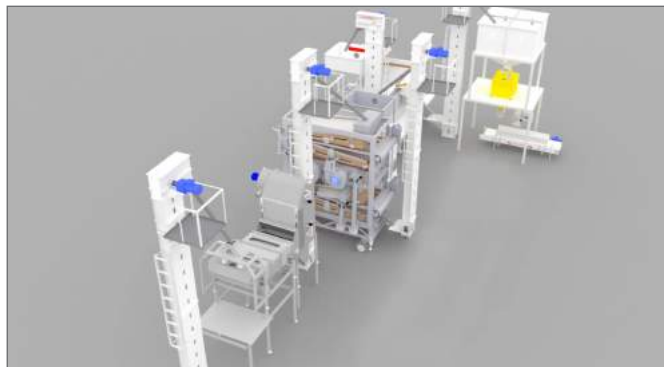

# Filling & Packing Application Samples

## Bung Hole Type Container Filling

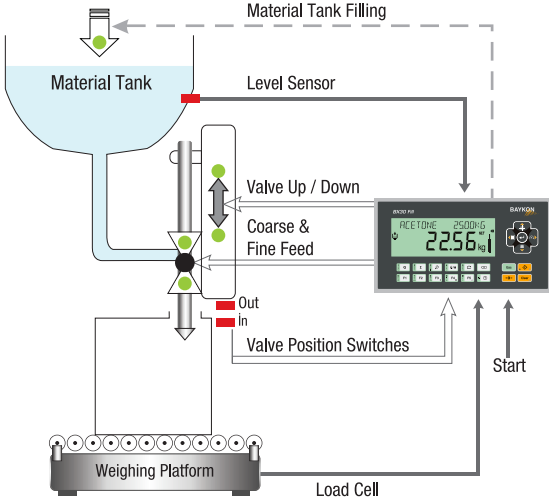

## Pallet Filling in High resolution (200 kg x 0,1 kg)

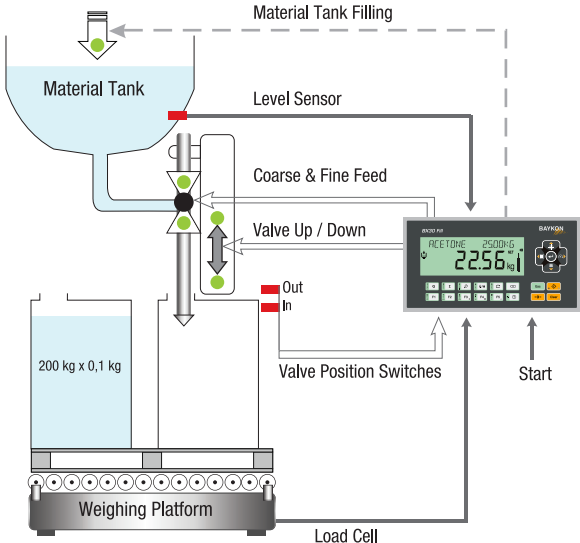

## Packing

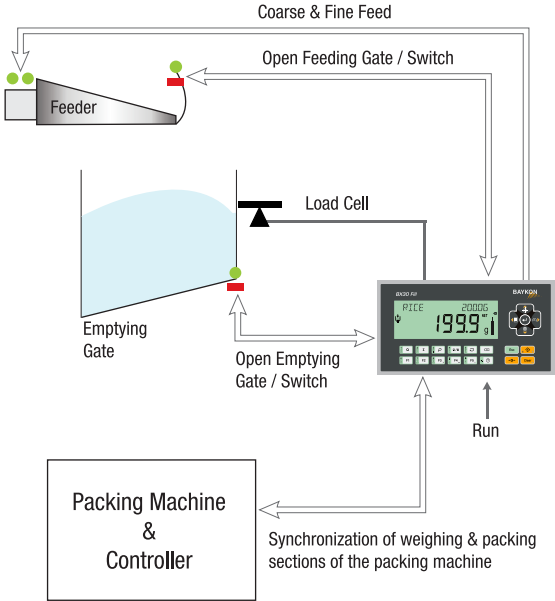

## Big Bag

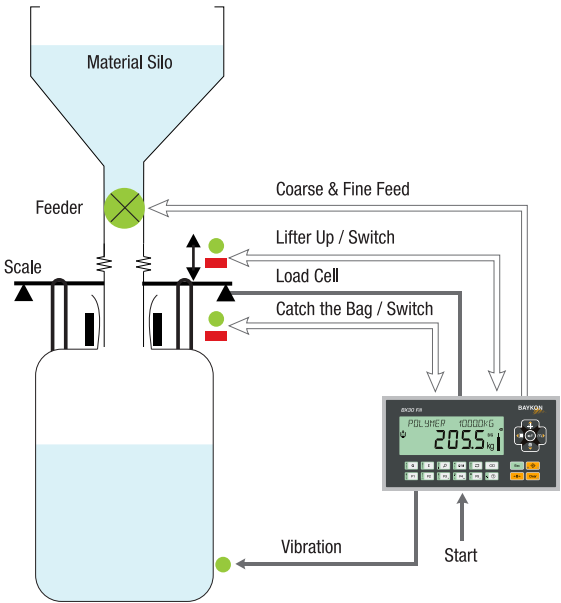

## Bagging Machine with Single Scale

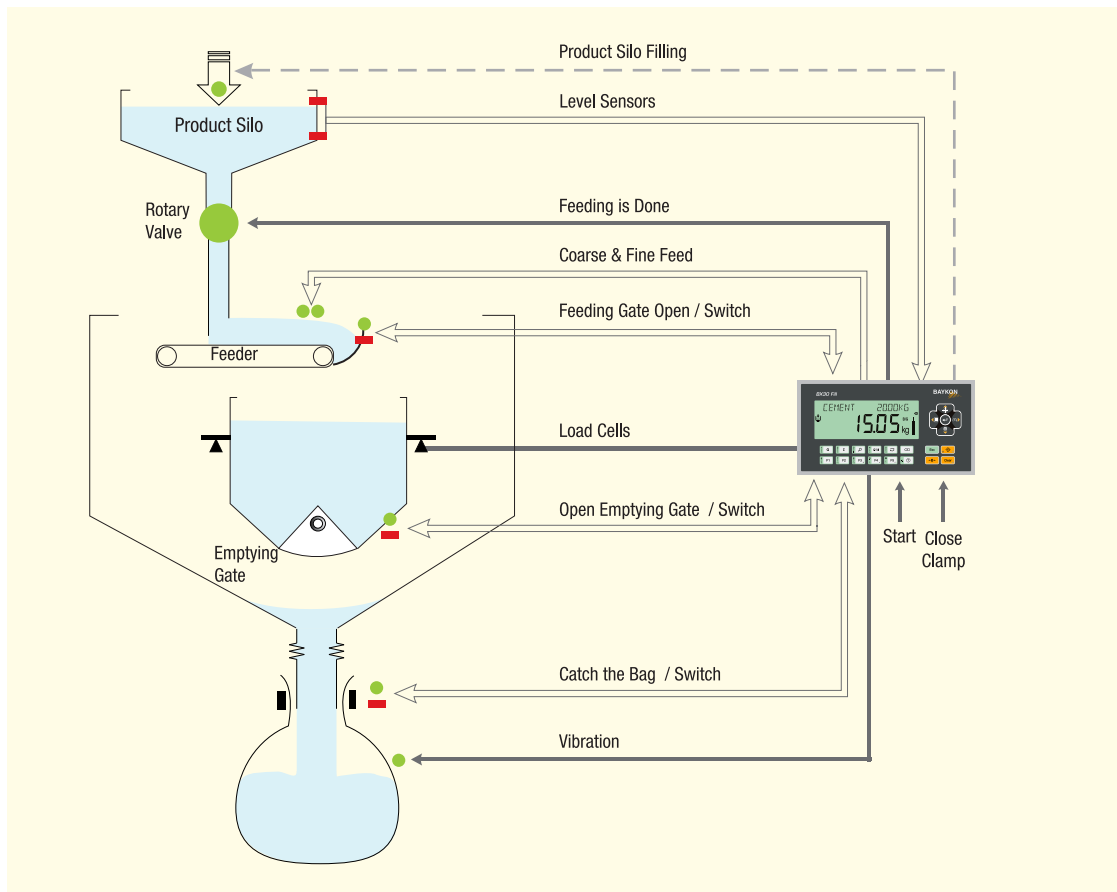

## Bagging Machine with Double Scales

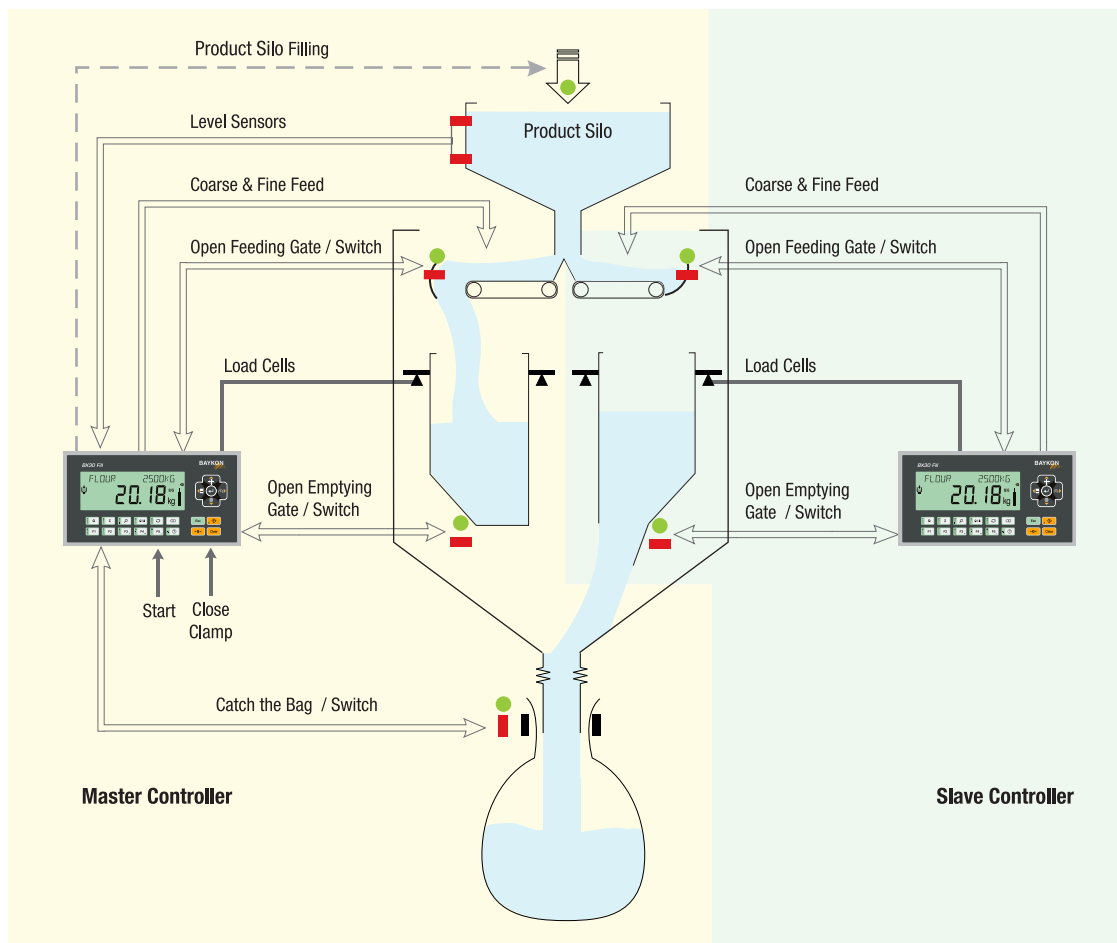

Extraction Rate Control

EU MID Approved

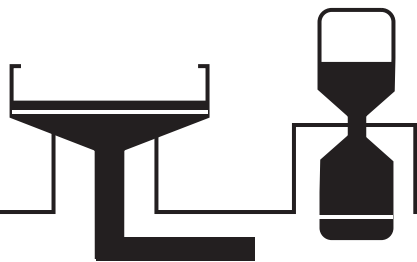

**Discontinuous Totalizer**

# Discontinuous Totalizer and Extraction Rate Control

## Real time control, high accuracy and high speed at automatic weighing with BAYKON technology and know-how..

Baykon discontinuous totalizing controllers are high tech, smart and economic instruments for usage at various discontinuous totalizing machines. Their operation modes fit to control the most common machines. With their advanced and intelligent electronic technologies, Baykon controllers meet all your requirements from basic discrete weighing to the most complex applications. Integration of Baykon controllers to the factory automation system - like SCADA, PLC , PC etc - is very simple!

Real time extraction flow rate control can be done at every discharging.



**BX14**

- Approved for EU MID and OIML R61, Ref class 0.2.
- Single range weight indication up to 300 000 division.
- Up to 1600 measurements per second.
- Filling control accuracy is 10 times higher than display division.
- Real time extraction flow rate control.
- Machine with single weighing hopper automation.
- Easy access to the recipe, target and cut off values.
- Galvanically isolated 4 digital input and 5 digital outputs..
- RS232C and RS485 standard interfaces.
- Wide range Fieldbus interfaces are available: Profibus, Profinet, Modbus RTU, Modbus TCP, EtherNet/IP, EtherCAT, Powerlink, CANopen, CC link and Profinet S2 for redundant systems.
- Small and compact panel type housing. Its panel cut-out fits 48 x 96 mm standard panel size.



**BX30 Total**

- Approved for EU MID and OIML R61 , Ref class 0.1.
- Single range, multi range and multi interval weight indication up to 300 000 division.
- Up to 1600 measurements per second.
- Filling control accuracy is 1000 times higher than display division.
- Real time extraction flow rate control and displaying it on the information display.
- 3 different operation modes: Single weighing hopper, single weighing hopper with prefeeding and double weighing hoppers.
- Configurable recipe content. Easy access to target, cut-off values and recipe with specified keys.
- Galvanically isolated external 16 digital input and 16 digital output.
- 250 pcs recipe memory and 250 pcs memory for identification data.
- Pre-feeding control with timer, with level sensor or with buffer hopper weighing.
- Programmable digital I/O for peripheral control points like vibration, air pressure switch, outlet is full etc.
- Ethernet, USB, RS232C and RS485 standard interfaces.
- Wide range Fieldbus interfaces are available: Profibus, Profinet, Modbus RTU, Modbus TCP, EtherNet/IP, EtherCAT, Powerlink, CANopen, CC link and Profinet S2 for redundant systems.





## High accuracy at Discrete Weighing and Flow control with BAYKON technology and know-how.

### SmartAPP

This feature gives the operator an advantage to follow the operation on the display with back light colours and bar graph. Smart adjustment technics provides realtime flow control, fast and accurate commissioning and usage.

### Master –Slave Connection

Master-slave inter connection between BX30 Total controllers provides;

- ✓ Transferring the set-up and recipe data to slave instruments
- ✓ Full control of the machine which has double scale.

### Measurement Methods

- ✓ Filled material weight measurement.
- ✓ Transferred material weight measurement.

### Operation Modes

- Provides easy commissioning.
- ✓ One weighing hopper
  - ✓ Weighing hopper with pre-feeding
  - ✓ Two weighing hoppers

### Easy Usage

Shortcut keys to enter target, coarse and fine cut-off values. Recipe key provides fast recipe changing. Programmable 5 keys for your effective usage. Bulk weighing at high accuracy 0.2% ( approved ) !

### Fast and Accurate

Up to 16000 conv/sec.  
16 000 000 internal resolution  
OIML approval for 0.2% accuracy.  
Industrial accuracy 0.1%.



### Standard Interfaces

- Ethernet TCP/IP
- USB
- 2X RS 232C
- RS 485

### PLC Interfaces :

- Profibus
- Profinet
- Profinet S2 redundancy
- Modbus RTU
- Modbus TCP
- EtherNet/IP
- EtherCAT
- CANopen
- CC-Link
- CC-Link IE
- Powerlink
- Digital I/O
- Ethernet TCP/IP

### Digital Inputs and Outputs

In-house digital 12 In/14 Out board or DIN rail mount RIO16 digital 16 In/16 Out unit. All I/O's are galvanically isolated and outputs are short circuit protected. The operator is warned in case of any open or short circuit at any output! In case of any digital I/O failure, one of the reserved I/O ports can be swapped with the faulty one to continue the operation until receiving the new digital I/O board.



## With Single Weighing Scale

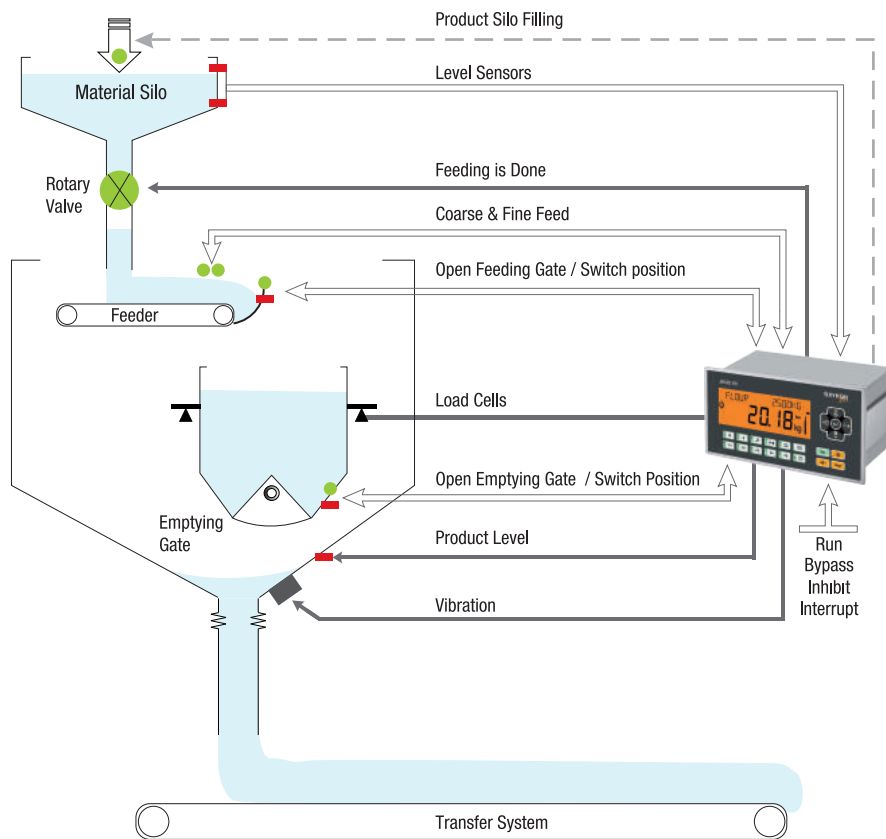

## With Buffer Hopper

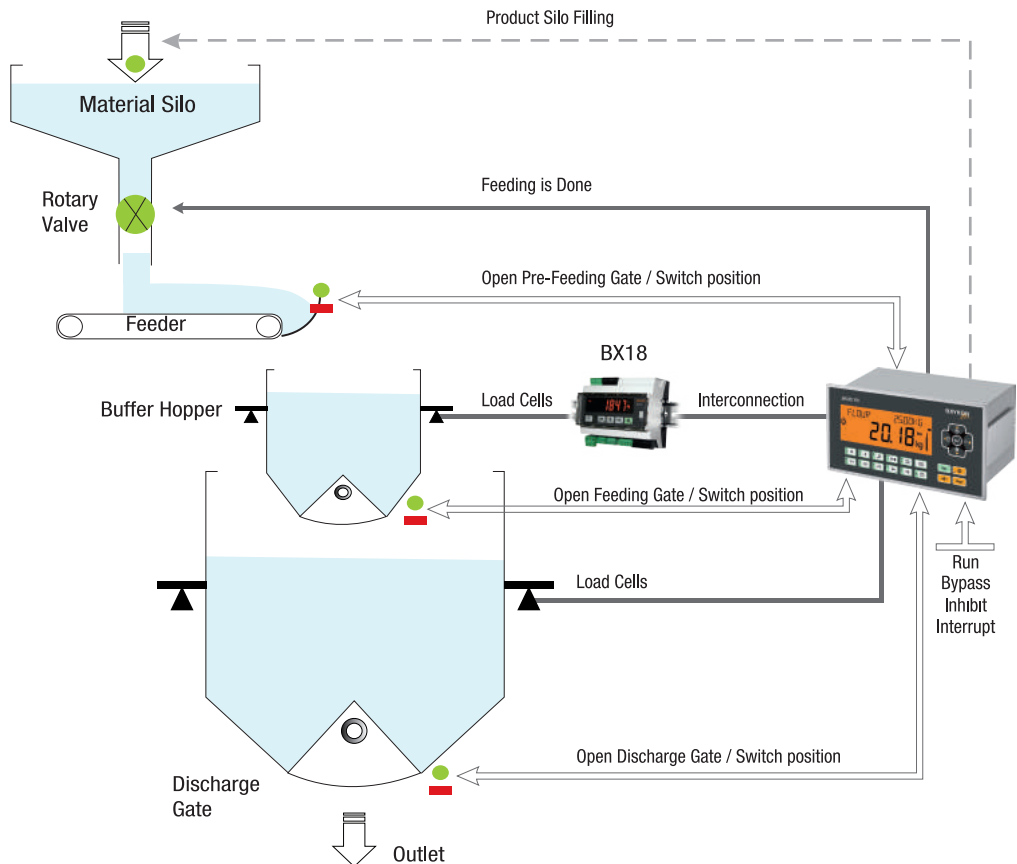



# Automatic Weighers

For Boxes and Bulk Materials



# Checkweighers



# Checkweighing / Catchweighing and Sorting



## High accuracy and speed at automatic weighing with BAYKON technology and know-how.

Baykon BX30 Check controller provides dynamic and static weighing of articles on the conveyor. The weighing process can be done with or without sensor on the weighing conveyor or at eject. With its advanced and intelligent electronic technologies, Baykon controller meets all your requirements from the basic weighing up to 10 range sorting of the articles. Integration of Baykon controllers to the factory automation system - like SCADA, PLC, PC etc - is very simple!

### SmartAPP

This feature gives the operator an advantage to follow the operation on the display with back light colours and bar graph.

### Changing Display Colour



### Bar Graph



### Acoustic warning



### Easy Usage

Short-cut keys to enter target, and tolerance. Recipe key provides fast article changing. Programmable 5 keys for your effective usage. Check weighing at high accuracy 0.1% ( approved ) !

### Fast and High Accuracy at Static or Dynamic Weighing

Up to 16000 conv/sec.  
16 000 000 internal resolution  
Operation with or without sensor on the conveyor.



### Standard Interfaces

- Ethernet TCP/IP
- USB
- 2X RS 232C
- RS 485

### PLC Interfaces :

- Profibus
- Profinet
- Profinet S2 redundancy
- Modbus RTU
- Modbus TCP
- EtherNet/IP
- EtherCAT
- CANopen
- CC-Link
- CC-Link IE
- Powerlink
- Digital I/O
- Ethernet TCP/IP

### Digital Inputs and Outputs

In-house digital 12 In/14 Out board or DIN rail mount RIO16 digital 16 In/16 Out unit. All I/O's are galvanically isolated and outputs are short circuit protected. The operator is warned in case of any open or short circuit at any output! In case of any digital I/O failure, one of the reserved I/O ports can be swapped with the faulty one to continue the operation until receiving the new digital I/O board.

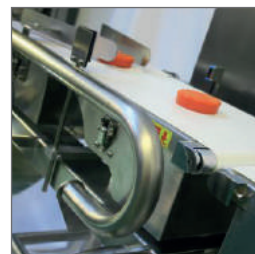



Eliminates Operator Mistakes  
Confidence at High Production Speed



**Packing & Portion Scales**

# For Fast, Accurate and Fruitful Packing Processes

BAYKON offers a variety of scales and packaging solutions that ideally fit for your packaging and portion preparation needs. An accurate, reliable, durable ,and cost-effective scales will improve production quality, reduce waste and improve productivity from day one.

Thanks to our software solutions, you can control your packaging process, measure operator performances, collect production data and export it to your ERP or Cloud, get statistical reports or anything else. Be prepared for the digital world of the near future, even if you don't need it today.

Proceed by choosing the process that suits you best...



## Individual net or gross packaging on the scale

This method is used to pack products one by one on the scale. The operator only follows the color of the screen during the process, which increases the efficiency of the operator and the system. With automatic zeroing, automatic taring, automatic data transfer, automatic labeling, etc. functions, the speed of the packaging line is increased.



## Filling the packages in the big case on the scale

This method is used to fill the products into the packages in the case on the scale. The operator fills packages in sequence by following only the color of the display, which increases the efficiency of the operator and the productivity of the system. Taring, Data transfer etc. are done automatically in process to increase the production line speed besides the fast speed of the scale.



## Packing by taking away from the full case on the scale

The container full of product is placed on the scale and the system measures the product weight or count taken a way from the container. The operator fills the packages by following only the color of the display. During packing process automatic Zeroing and Taring, Data export etc. is done automatically which increases the efficiency of the operator and the productivity the system.



## Portion Scale

Portion scales are mostly used in meat and poultry industries to prepare portions. The cutting of the product is done on the scale which requires the scale produced for harsh usage. Touchless usage is important due to easy operation, hygienic condition and protection of the instrument. Touch free keys of Baykon BX25 indicator with Baykon software offer perfect solutions for portion preparing processes.



If you could not see your application above, contact with BAYKON to find solution.

# Choose the BAYKON Scale suitable for your packing process;

## BAYKON packing and portion scales provides;

- ✓ No need to follow weight value on the display,
- ✓ Color changing display for operator guiding,
- ✓ Packing process with automatic zeroing, taring and print out,
- ✓ Easy, fast, accurate and reliable operation,
- ✓ Touchless key functions defined for zeroing, taring, print, etc. Just scan your hand or cutting knife in front of the distance adjustable infrared keys!
- ✓ SmartApp® for online monitoring of weighing transaction,
- ✓ 500 pcs article memories in the terminal for off line operation,
- ✓ Online product information; number of packages, batch information, statistical data such as average weight, standard deviation etc.
- ✓ Embedded software protocols for ERP integration, data processing software developers,
- ✓ Logger to save up to 10.000 transactional records



<p><b>BCS21</b></p> 	<p><b>BCS21S</b></p> 	<p><b>BT2430</b></p> 	<p><b>BT3040D</b></p> 
<p><b>Capacity</b> : 3 - 30 kg  <b>Platform size</b> : 24 x 30 cm  <b>Measuring time</b> : 0,7 second.  <b>Features</b> :                      - Color changing display                      - 100 pcs Article memory,                      - 2 x 3000d OIML approved,                      - RS232C data output to PC,</p>	<p><b>Capacity</b> : 3 - 30 kg  <b>Platform size</b> : 24 x 30 cm  <b>Measuring time</b> : 0,7 second.  <b>Features</b> :                      - Color changing display,                      - 100 pcs Article memory,                      - 2 x 3000d OIML approved,                      - RS232C data output to PC,</p>	<p><b>Capacity</b> : 3 - 30 kg  <b>Platform size</b> : 24 x 30 cm  <b>Measuring time</b> : 0,7 second.  <b>Features</b> :                      - Color changing display,                      - 500 pcs Article memory,                      - 2 x 3000d OIML approved,                      - RS232C data output to PC</p>	<p><b>Capacity</b> : 3 - 30 kg  <b>Platform size</b> : 30 x 40 cm  <b>Measuring time</b> : 0,7 second.  <b>Features</b> :                      - Color changing dual display,                      - 500 pcs Article memory,                      - 2 x 3000d OIML approved,                      - RS232C data output to PC</p>
<p><b>BT3040</b></p> 	<p><b>BT4560</b></p> 	<p><b>BT6080</b></p> 	<p><b>BX65 / BX66 &amp; BT.....</b></p> 
<p><b>Capacity</b> : 3 - 30 kg  <b>Platform size</b> : 30 x 40 cm  <b>Measuring time</b> : 0,5 second.  <b>Features</b> :                      - Color changing display,                      - 500 pcs Article memory,                      - Touchless Infrared keys,                      - 3 x 3000d OIML approved.                      - RS485, USB, Ethernet TCP/IP                      - Data export to Cloud, IoT, etc</p>	<p><b>Capacity</b> : 30 - 150 kg  <b>Platform size</b> : 45 x 60 cm  <b>Measuring time</b> : 0,5 second.  <b>Features</b> :                      - Color changing display,                      - 500 pcs Article memory,                      - Touchless Infrared keys,                      - 3 x 3000d OIML approved.                      - RS485, USB, Ethernet TCP/IP                      - Data export to Cloud, IoT, etc.</p>	<p><b>Capacity</b> : 60 - 300 kg  <b>Platform size</b> : 60 x 80 cm  <b>Measuring time</b> : 0,5 second.  <b>Features</b> :                      - Color changing display,                      - 500 pcs Article memory,                      - Touchless Infrared keys,                      - 3 x 3000d OIML approved.                      - RS485, USB, Ethernet TCP/IP                      - Data export to Cloud, IoT, etc</p>	<p><b>Capacity</b> : 3 - 300 kg  <b>Platform size</b> : Various  <b>Measuring time</b> : 0,5 second.  <b>Features</b> :                      - Color changing display,                      - 5000 pcs Article memory,                      - 3 x 3000d OIML approved.                      - Operating system Win CE or Windows10lot                      - USB, Ethernet TCP/IP                      - Data export to Server, ERP etc.</p>

**Important Not:** Features are depend on the selected weighing indicator or terminal. Customized solutions are available.

# Data Processing with BAYKON Networked Packing Solutions

Baykon offers various software for data recording and reporting for packaging applications in the food and chemical industries. Multi-scale packaging lines can be monitored and controlled from the production manager's computer.

Production data can be exported to ERP system in different ways such as cloud or IoT platform, Web Service etc. The various reports, such as production, statistical, performance measurements of operators, etc., can be edited.

- ✓ Packing operation only with changing display color.
- ✓ Quick and easy operation with automatic zeroing, taring and data export.
- ✓ Operator guiding with text messages on weighing terminal.
- ✓ Package, or container and palette labeling.
- ✓ Product selection with barcode reader.
- ✓ Lot, statistical, article, shift and daily etc.reports.
- ✓ Direct ERP integration. Importing product data and set values from ERP and exporting actual weighing records to the ERP to get reports from ERP system. weighing records to the ERP Get reports from ERP system.
- ✓ Integrated IoT option to transfer measurement data to the Cloud.
- ✓ Measuring operator performance.
- ✓ Detailed production report.
- ✓ Data transfer for analyzing at excel or in your system software.

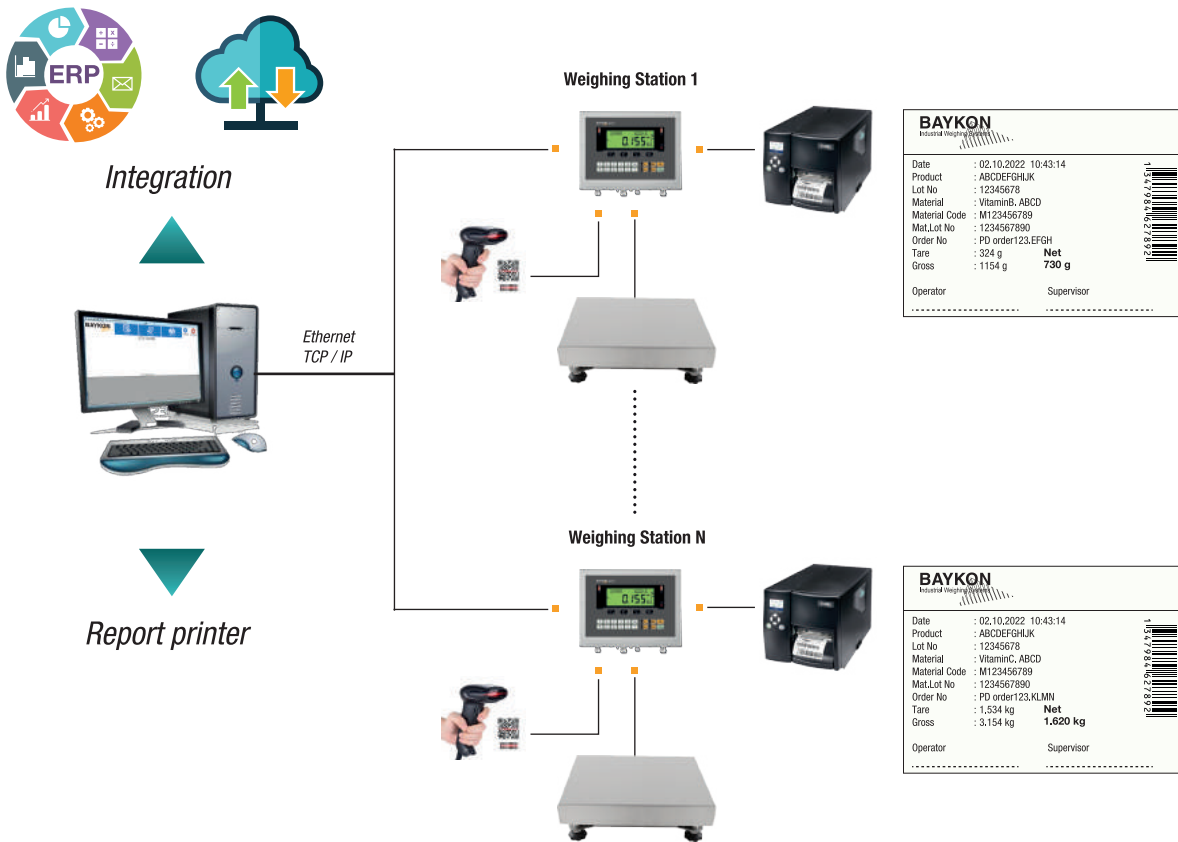



**Intelligent, Safe and Accurate Weighing**

**Fully Integrated With Your ERP System**



**Formulation &  
Additive Weighing**

# Accurate Weighing of the Right Product in Full Compliance With the ERP System

Formulation is one of the most important weighing processes for recipe preparation and weighing additives, especially in the pharmaceutical, food and chemical industries. The correct and reliable formulation process directly affects product quality and efficiency.

Baykon iForm is a very powerful software that can directly access work orders, recipe formulations and raw material data in the ERP system, ensures that the right raw material is weighed on the right scale within the specified tolerances, traces the scale calibrations and mass certificates. Baykon iForm software and weighing instruments comply with international standards such as GMP, HACCP, etc. and can be verified by the experienced Baykon service team.

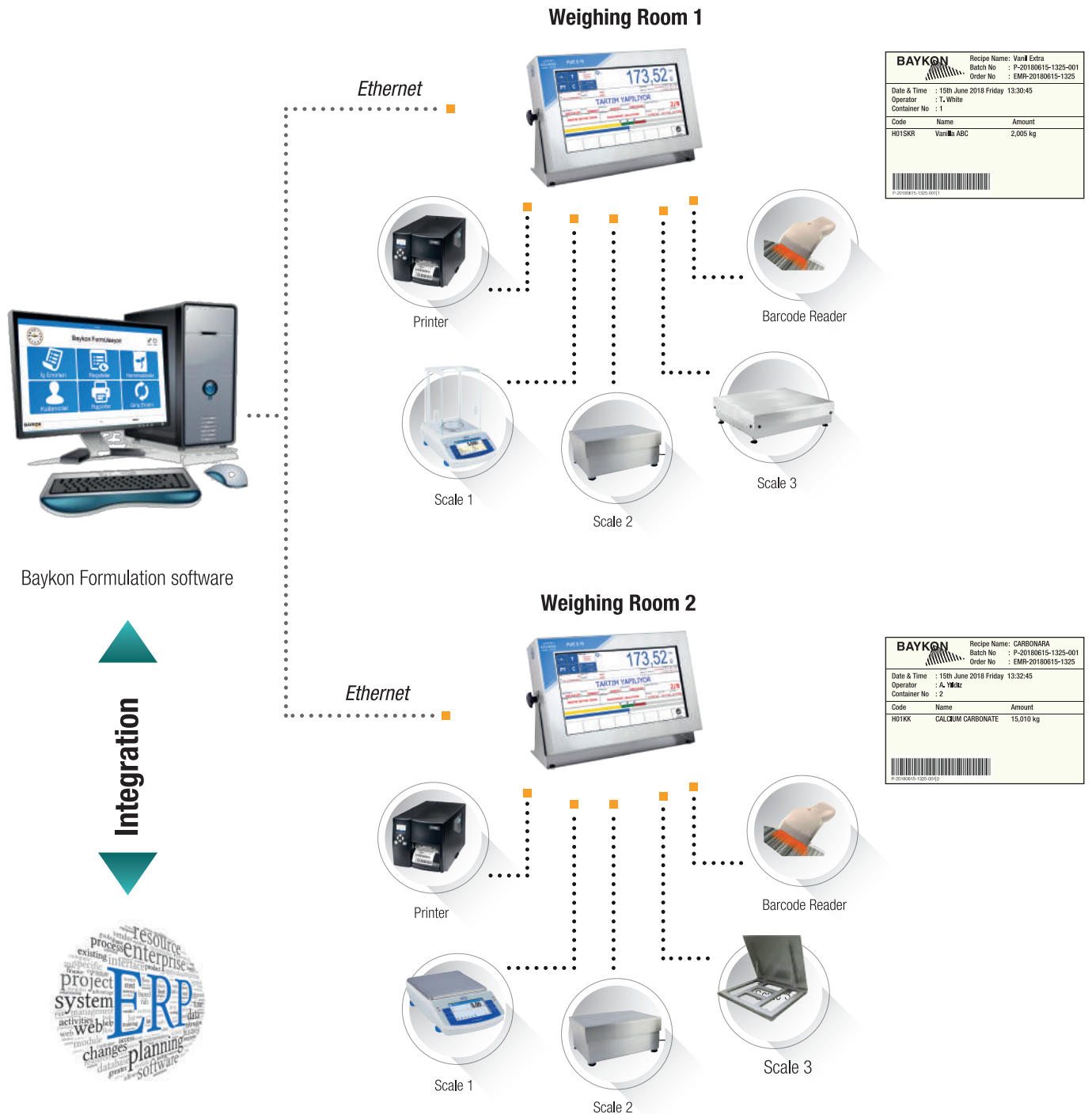

## Formulation in Product Development

The proportions of raw materials in the products are determined by the formulation development process. The product's desired properties, such as taste, smell, color, etc. , are obtained by repeated test weighing and revisions of the components. Recording the weighing values and test results of the components in these test recipes is a very important requirement for R&D. Baykon Formulation software offers you the opportunity to record and report data on recipe revisions and results to improve your product.



# Why Baykon iForm is the Best?

Baykon iForm Formulation Software has been developed based on more than 30 years of experience in the Pharmaceutical, Cosmetic and Food industries. Thanks to the Baykon iForm Formulation System ensures weighing the right raw material with the right lot number, accurately and within the specified tolerances. It works in sync with the ERP system, produces the requested labels to ensure traceability and records all weighing results. If it is required, the recipe formula can be hidden in the weighing process.

iForm guides weighing room operators, provides them with comfortable working conditions and safety.

- ✓ Weighing the right product within the specified tolerances, producing labels for traceability.
- ✓ Guiding the operator to prevent operator errors.
- ✓ Setting traceable and secure system from the work order entry to product preparation.
- ✓ Full integration with ERP
- ✓ Intelligent correction of over weighings.

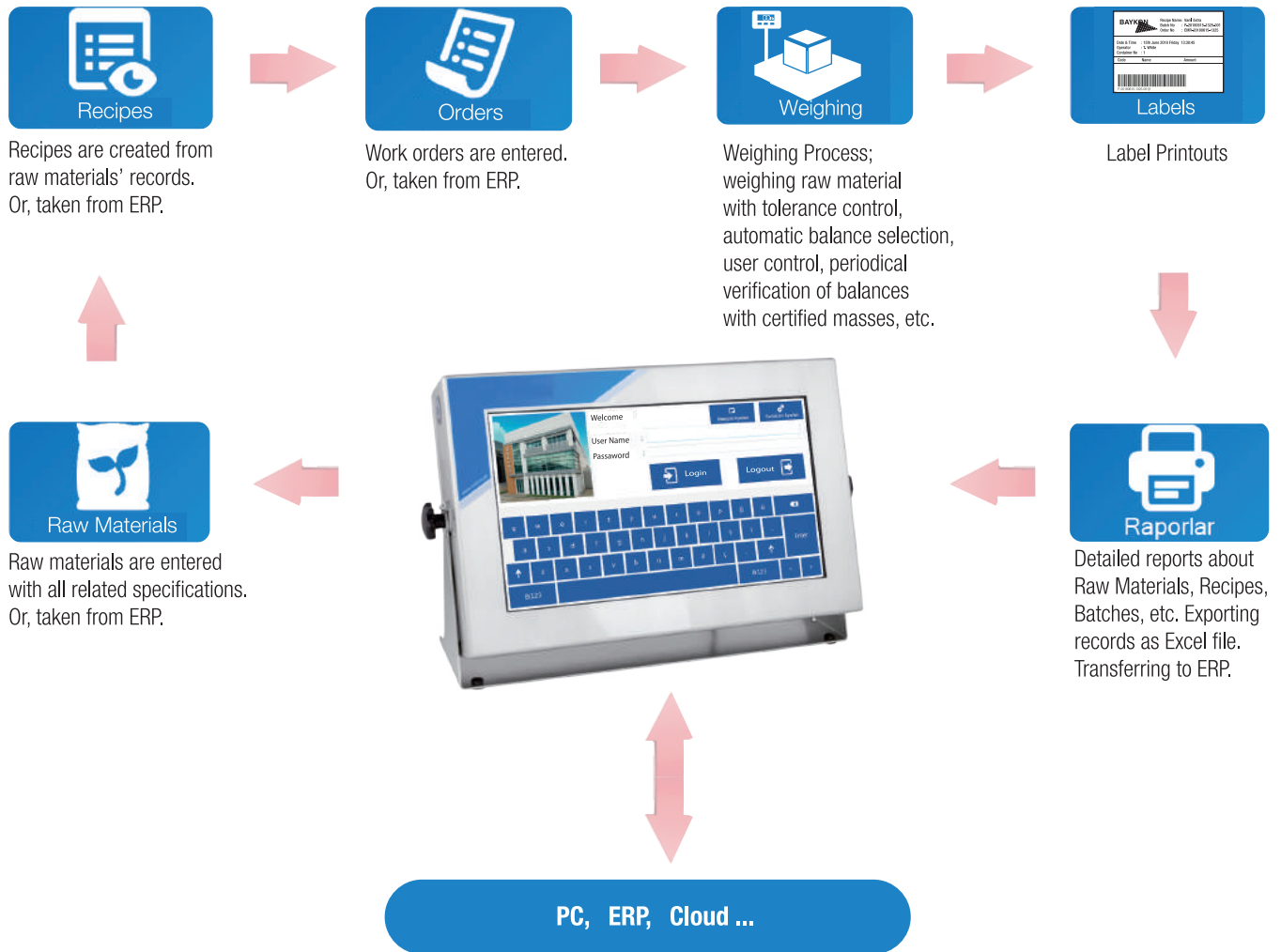

## Intelligent Formulation With iForm

The over weighing of any material can be automatically corrected by activating the intelligent function of the software to get the accurate material ratios. Activating intelligent function of the system minimizes the operational weighing errors especially at vertical formulations which is weighing raw materials in the same container.

## Validated software solution

Baykon iForm is validated according to international standards by the experienced Baykon service team to ensure that results are accurate, valid and reliable.

# Features and Benefits of Baykon iForm

Formulation process directly affects the product quality and the cost of the production by reducing the raw material loss and by increasing the efficiency. Raw materials are weighed within the correct product tolerances. The formulation process is executed with a state-of-the-art weighing terminal that carries out the synchronization between the powerful formulation software and the ERP.

## Controlled Recipe Weighing

- ✓ Checking the correct recipe
- ✓ Checking the right product
- ✓ Choosing the right scale according to requested accuracy
- ✓ Weighing raw materials within the specified tolerances
- ✓ Printing the raw material and lot labels with barcodes
- ✓ Controlling validity of the calibration certificate of scales
- ✓ Checking and ensuring safe working conditions

## Direct ERP Integration

- ✓ Transferring work orders from ERP
- ✓ Accessing of current recipe formulations
- ✓ Recipe formulation is performed based on records of raw material and recipe formulations in ERP
- ✓ Transferring actual weighing records to the ERP system
- ✓ Detailed reports for work orders, prepared recipes and raw materials usage are given



## Labels and Reports

With Baykon iForm software, Raw Material Weighing Label, Group Raw Material Label that belongs to the raw material group weighed in the same package, and Lot Label can be specially designed.

Customized reports such as Recipe Weighing, Material Usage, Work Order Status, Batch Status, Scale Verification, and Production Usage (which is used to assist during production) are given.

## Raw Material Weighing Label

<b>BAYKON</b>			Recipe Name: Vanil Extra
			Batch No : P-20180615-1325-001
			Order No : EMR-20180615-1325
Date & Time	: 15th June 2018 Friday 13:30:45		
Operator	: T. White		
Container No	: 1		
Code	Name	Amount	
H01SKR	Vanilla ABC	2,005 kg	
 P-20180615-1325-0011			

## Bacht Label

<b>BAYKON</b>			Recipe Name: Yeast Tredional
			Batch No : P-20180615-1325-001
			Order No : EMR-20180615-1325
Date & Time	: 15th June 2018 Friday 13:55:45		
Operator	: A. Yildiz		
TOTAL WEIGHT:	17,015 kg		
Name	Container No	Amount	
Pigment	1	1,005 kg	
Fermant	2	15,010 kg	
 P-20180615-1325-001			

## Report

**Report Form**

Order Status Report   Weighing Report   Feed Report   Recipe Report   Raw Material Usage Report   Raw Material Consumption Report

**Order Status Report**

Start Date Time : 01/01/2018 00:00:00

End Date Time : 03/07/2018 23:59:59

Get Report

  

**Form Preview**

Order No	Batch No	Created Date	Status
Emir222	1804000026	3.04.2018 11:46:40	Waiting for weighing.
Emir222	1804000026	3.04.2018 11:46:40	Waiting for weighing.
Emir222	1804000027	3.04.2018 11:46:40	Waiting for weighing.
Emir222	1804000028	3.04.2018 11:46:40	Waiting for weighing.
Emir222	1804000029	3.04.2018 11:46:40	Waiting for weighing.
Emir222	1804000030	3.04.2018 11:46:40	Waiting for weighing.
MZS1	1804000031	6.04.2018 04:47:09	Feeding completed.
MLKMLK	1804000032	28.04.2018 23:53:19	Waiting for weighing.
BH-EMIR1	1805000001	9.05.2018 16:55:08	Weighing completed.
BH-EMIR2	1805000002	9.05.2018 16:10:51	Weighing completed.

# Smart Integration of Weighing

Extreme Accuracy,  
More Reliability,  
Easy Calibration & Fast Maintenance.

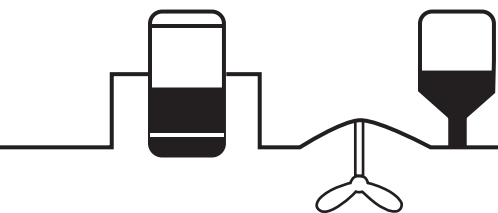

## Tank, Reactor and Silo Scales





# Is a Tank Weighing System only Implementing Load cell in your Process ?

The accuracy and reliability of a tank /reactor / silo scales are determined by a combination of several factors, including weighing indicator, load cells, mechanical design, mounting hardware and environmental influences. Accurate measurement, especially batching, dosing or filling processes require high quality system configuration.

BAYKON tank scale components provide best performance for your weighing systems by increasing the accuracy, reliability, easy calibration and minimized service. Having a high quality tank scale, including precision components and supplier know-how, minimizes your cost due to eliminating weighing and processing problems, and increasing your production quality.

The selected weigh module affects the accuracy and safety of a tank scale system which must be considered during the design stage. If a scale will be subject to wind, seismic, or shock loading, you might need to be more careful at your component selection. Contact BAYKON experienced sales engineers to design your hardware.



			
<p><b>Versatile Weighing</b></p> <ul style="list-style-type: none"> <li>• Stand alone silo, tank, vessel scales,</li> <li>• Fieldbus integration for weighing in process,</li> <li>• Accurate and reliable dosing, batching, blending, filling, discharging.</li> <li>• Inventory control etc.</li> <li>• Reliable Level measurement.</li> </ul>	<p><b>Smart Operation</b></p> <ul style="list-style-type: none"> <li>• Intelligent and high speed weighing indicators and terminals,</li> <li>• Intelligent filling &amp; discharging algorithms,</li> <li>• Accurate &amp; reliable weigh modules,</li> <li>• High speed &amp; accurate measurement.</li> </ul>	<p><b>Advanced Technology &amp; Performance</b></p> <ul style="list-style-type: none"> <li>• High speed real time processing,</li> <li>• Extremely high conversion rate, up to 1600 conversion per second,</li> <li>• 1000 times higher processing resolution than scale increment,</li> <li>• Freely programmable terminals with up to digital 32 In / 32 Out.</li> </ul>	<p><b>Integration &amp; Connectivity</b></p> <p>Real time communication</p> <ul style="list-style-type: none"> <li>• Ethernet TCP/IP, USB, RS-232C, RS-485,</li> <li>• Profibus, Profinet, Modbus RTU, Modbus TCP, EtherCAT, CANopen, CC-Link, CC-Link IE, Powerlink,</li> <li>• DIN rail digital I/O unit for easy cabling in the cabinet,</li> <li>• Cloud connection, Industry 4.0.</li> </ul>

# High accurate and reliable weighing terminals for tank weighing with BAYKON technology & know-how.

With its advanced and intelligent electronic technologies, Baykon weighing electronics meet all your requirements from basic to the most complex tank weighing applications. Integration of Baykon instruments to the factory automation system - like a PC / PLC / Scada etc. - is very simple! And today's world, Ethernet port on the instrument should be, and can not be even an option!

## SmartAPP<sup>®</sup>

This a special function helps the operator to follow the steps of the weighing process on the display.



## Guiding the Operator With Color Change

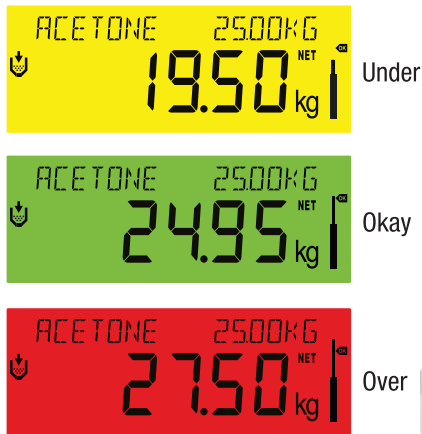

## Easy & Flexible Calibration

All Baykon weighing indicators and terminals have eCAL electronic calibration method; adjustment without test weights provides big advantage especially for heavy capacity tank and silo scales having loading difficulties. Span calibration of loaded tanks which cannot be emptied.

## Fast and Effective Service

Scale history log and remote service are only some advantages of Baykon electronics for easy and effective service.



## Communication and Integration;

Powerful communication, fieldbus interface and easy system integration functions. Even if you don't need it today, it will be easy to modernize your production in the future with these optional features.

## Wide Range of Weighing Instruments;

Contact Baykon to offer you the best instrument from a wide range of products, from basic electronics to complex weighing terminals.

## What is the Weighing Accuracy;

The high resolution indication does not mean high accurate weighing. The scale accuracy might be very low even at very high resolution weight displaying. Select high accurate and reliable weighing electronic to eliminate the weighing error coming from electronic instrument. BAYKON weighing indicators with their state-of-the-art features provide perfect results at tank weighing applications to get best performance.

# Accurate and Reliable Tank Weighing Requires Professional Designed and Produced Weigh Modules With Know-how.

With its advanced and intelligent electronic technologies, Baykon weighing instruments meet all your requirements from basic to the most complex tank weighing applications. Integration of Baykon instruments to the factory automation system - like a PC / PLC / Scada etc. - is very simple!

## Horizontal Movement Protection

Mounting hardware has protection to prevent vessel horizontal movement and tipping.

## Wide Product Range

You can easily select the most convenient weighing mount hardware for your application. Various load receiving variants maintains proper force transmission for accurate weighing, against vibration, thermal expansion and shock loading.

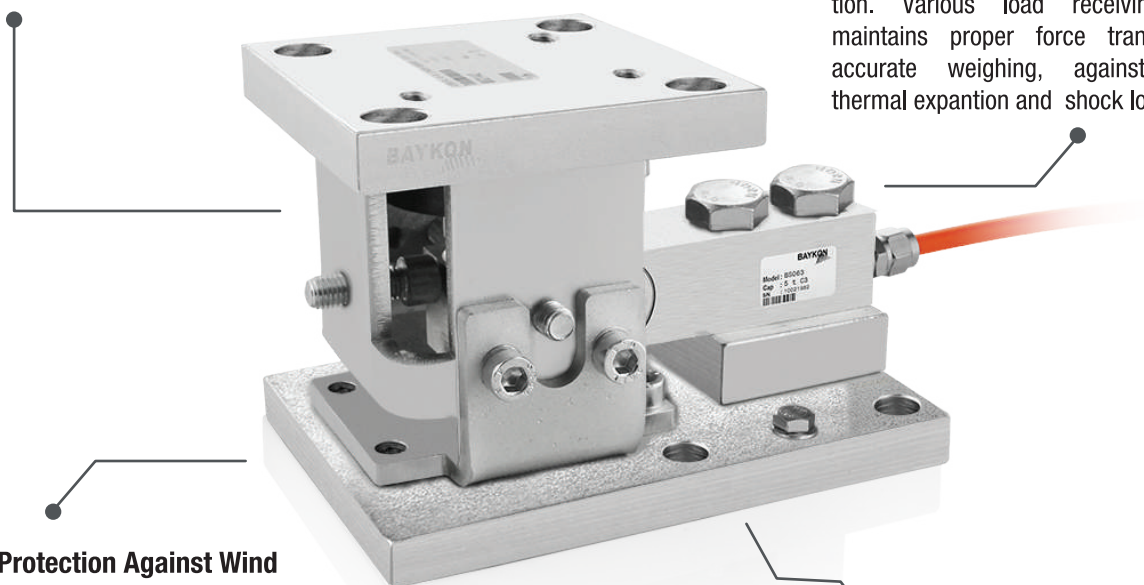

## Lift-off Protection Against Wind

Overturn protection for outdoor tanks and silos against the wind and lift-off protection for the indoor tanks.

## Load Cell Free Mechanical Installation

Mechanical installation can be done without load cells. Load cell assembling at start-up do not require any jack.

## Corrosion Resistance

Various Stainless steel and Corrosion resistant models against chemicals. Optional electrostatic painting, galvanized and even PVC coated types are available.



## When Sanitary is Vital ....

In Baykon, there is always the most convenient solution for your application. Call Baykon to get the suggestion of the experienced sales engineers on selecting the mounting hardware to minimize sanitary risks, vibration, and wind effects and increase the accuracy and reliability of the weighing system. Baykon solutions meet or exceed global standards.

# Would you like to Have More Reliable Tank Weighing System, Fully Digital Weighing System ?



BAYKON has a wide range of digital load cells which meet highest standards in various industries. All digital load cells are set up accurately in production process to get extremely high performance in the usage.



### Better Performance

Digital load cells are digitally compensated for high performance with filtering and increased electrical immunity with a microcontroller in each load cell.



### Prevents the Wrong Measurement.

Weighing system stops the operation in case of any detected malfunction by the weighing terminal. No any wrong weighing because of load cell malfunction.



### Eliminates Spoiling Influences

Safety operation under Temperature & Voltage variations. Radio and Electromagnetic effects are minimized.



### Heavy-duty Interfacing

The measured weight value do not affect from the water concentration at junction points and from damage of the cable.



### Advanced Features

The systems equipped with digital load cells have additional features due to digital technology in the load cell.

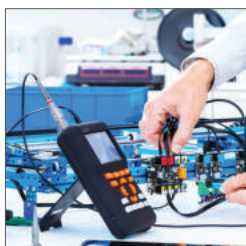

### Electronic Calibration

No corner adjustment with resistances. Recalibration is not required on indicator, cable, or Junction box replacements, thanks to the digital interface technology.

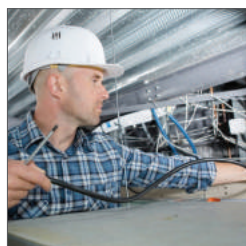

### Lowest Service Costs

Easy and quick fault finding, detects problems and simplifies service. After load cell change, use without re-calibration for non-legal for trade scales.

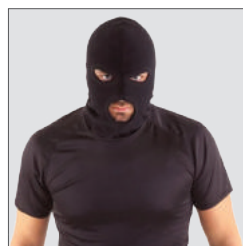

### Preventing Fraud & Cheating

Very difficult to cheat through secure digital BLDC RS 485 communication.



### Lightning & Surge Voltage Protection

LPK24 and LPK24D Lightning Protection Kits increase the system immunity against surge.



### Rust & Corrosion

The fully welded stainless steel structure, hermetically sealed, and IP68 protection class provides you with long-term reliability.

# Explosive areas need special consideration, but scale performance need not be compromised.

Baykon explosive area weighing equipment provide high speed process control for automated processes, multiple scale and ERP integration. You can select weighing electronics, load cells and junction box together with weighing module to configure ATEX or IECEx approved weighing system delivering safety and best accuracy.

Choose from a wide range of compact, bench, floor and custom scales as well as approved load cells, terminals and the best weighing module. Your selection should be convenient for your processing needs in the future investment.

Below you will find typical tank scale applications in production process.

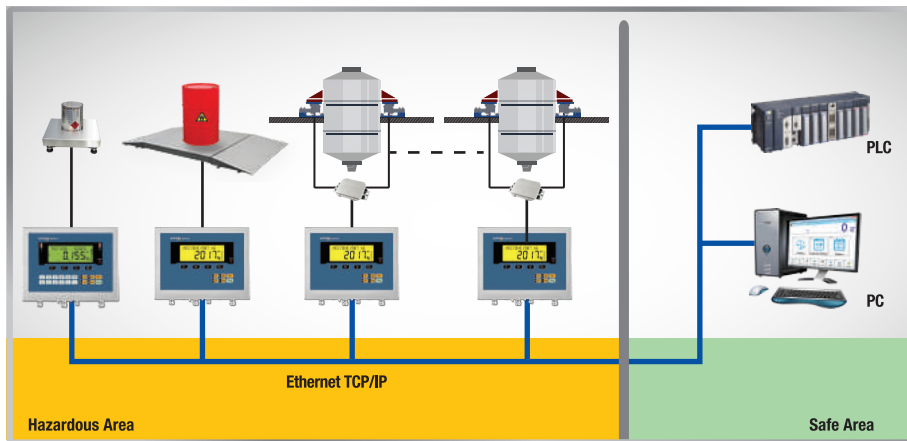

Interfacing the weighing equipments in the hazardous area

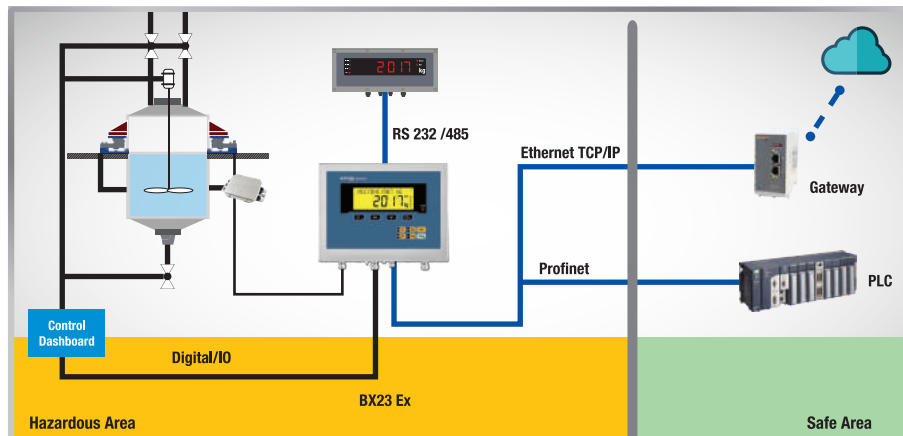

Process control of the vessel in the hazardous area

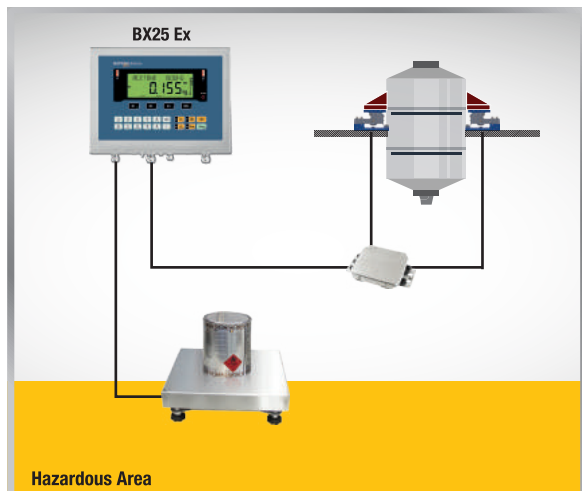











2 in one; tank and bench scale connected together to BX25. No need a second weighing indicator to add additives into your reactor. Direct Ethernet TCP/IP, Fieldbus connection and Analogue output for PLC/S-cada Integration.







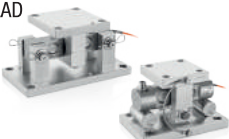





# Tank, Silo Weighing Applications & Mounting Kits

Application Type	Precision tank, reactor and vessel weighing	Accurate tank, reactor and vessel weighing	Low Accurate tank and vessel weighing	Level measurement of storage tank and silo
				
System Accuracy %FS	0.015 to 0.03	0.03 to 0.05	0.05 to 0.10	Greater than 0.1
Load cell accuracy	C6 , C5, C4, C3 OIML	C3, C2 OIML or non-OIML	C3, C2, C1 OIML or GP	C3, C2, C1 or GP
Dummy load cell	None	None	None	Preferable only for liquid and gas
Vibration	Not recommended	depend on scale design	Up to weigh module limits	Up to weigh module limits
Air current and Wind	Indoor applications	depend on scale design	Up to weigh module limits	Up to weigh module limits
Calibration technic	Test weight and material substitution	Test weight and material substitution, eCAL ( Plus ) with Geo adjust		eCAL ( Plus )
<b>Mounting Kits</b>				
LA54 		Load cell capacity : From 25 kg to 5000 kg Loading direction : Tension Protections : Against breaking Material : Galvanized steel, painted steel or stainless steel		
LA66-C/T 	Load cell capacity : From 10 kg to 500 kg Loading direction : Tension ( T type ) / Compression ( C type ) Protections : Overload, anti-lift Material : Galvanized steel, painted steel or stainless steel			
LEB-FT/FTM 	Load cell capacity : From 100 kg to 5000 kg Loading direction : Compression Protections : Anti-lift Material : Galvanized steel, painted steel or stainless steel			
LEB-RB 	Load cell capacity : From 100 kg to 5000 kg Loading direction : Compression Protections : Overload, anti-lift Material : Galvanized steel, painted steel or stainless steel			
LEB-FL/RC/SP 	Load cell capacity : From 100 kg to 5000 kg Loading direction : Compression, self-centering Protections : Overload, anti-lift, horizontal movement by bumpers Material : Galvanized steel, painted steel or stainless steel			
LAC 	Load cell capacity : From 1000 kg to 50000 kg Loading direction : Compression Protections : Anti-lift, horizontal movement, vibration absorber limiting horizontal displacement at earthquake. Material : Galvanized steel, painted steel or stainless steel			
LAD 	Load cell capacity : From 1000 kg to 50000 kg Loading direction : Compression Protections : Overload, anti-lift, horizontal movement Material : Galvanized steel, painted steel or stainless steel			

# Instruments

	Weighing Transmitters	BX10 / BX11 / BX13 Weighing terminals	BX23 / BX25 Weighing terminals	BX30 / 30 Plus / BX30 Fill Weighing terminals
				
Application type	Reactor, tank, silo weighing with PC and PLC interfacing. Level measurement	Tank, hopper, silo, conveyor systems, batching, filling.	Tank, hopper, silo, conveyor systems, batching, filling.	Tank, hopper, silo, conveyor systems, batching, filling.
Accuracy	< 0.05 % TX11 and TX12 < 0.02% others	< 0.01%	< 0.01%	< 0.01%
Load cell type	Analogue load cells	Analogue load cells	Analogue and digital load cells	Analogue and digital load cells
Analogue output	TX11, TX12 and TX13	optional	optional	optional
Interfaces	Std: RS232C, RS485 Fieldbus: TX2, TX4, MCS08 Ethernet: TX2, TX4, MCS08	Std: 2 x RS232C, RS485, Ethernet TCP/IP, USB Opt.: Fieldbus, Digital I/O	Std: 2 x RS232C, RS485, Ethernet TCP/IP, USB Opt.: Fieldbus, Digital I/O	Std: 2 x RS232C, RS485, Ethernet TCP/IP, USB Opt.: Fieldbus, Digital I/O
Cloud communication	NA	NA	IIoT ( optional )	NA

# Load Cells

	S Type	Beam Type	Ring Type	Column Type
				
Type	Analogue load cells	Analogue and digital load cells	Analogue and digital load cells	Analogue and digital load cells
Loading direction	Tension	Beam	Compression	Compression
Accuracy	GP, C3, C6	GP, C3, C6	GP, C3, C5, C6	GP, C3, C4, C5, C6
Capacity	5 kg - 1000 kg	20 kg - 10 tons	5 ton - 250 tons	7,5 ton - 400 tons
Material	Al, Nickel plated steel, Stainless steel.	Nickel plated steel, Stainless steel.	Nickel plated steel, Stainless steel.	Nickel plated steel, Stainless steel.



Atex Certified Weighing

Safety in Explosive Areas



**Ex-Proof Weighing Systems**

# Ex-Proof Weighing Systems

## Security First !!!

When necessary and approved precautions are taken, it is possible to instal weighing systems in explosive, flammable areas.

Baykon is at your side for your weighing systems needs containing ATEX approved weighing instruments to work in potentially explosive atmospheres with all flammable gases, liquid vapors, cloudy dust.

BAYKON has trained and experienced staffs about explosive areas to provide the right solution for you!

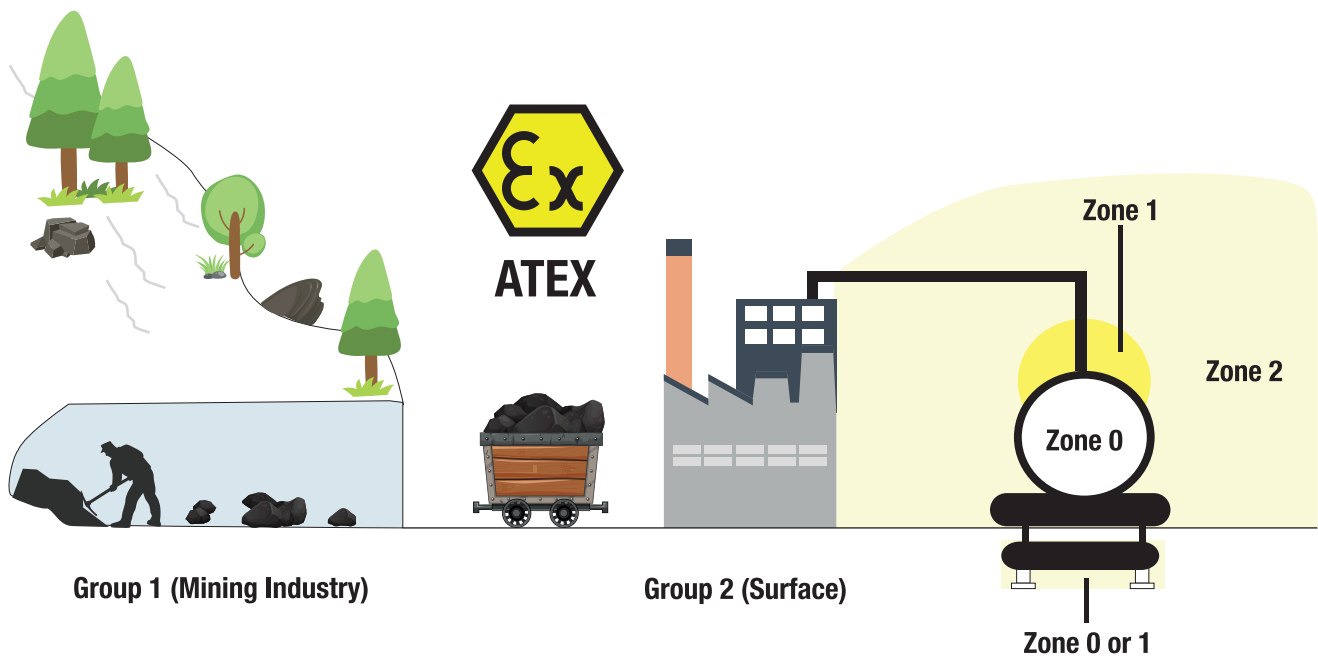

## ATEX Zone Classification

- Zone 0: A place in which an explosive atmosphere consisting of a mixture with air of dangerous substances in the form of gas, vapor or mist is present continuously or for long periods or frequently.
- Zone 1: A place in which an explosive atmosphere consisting of a mixture with air of dangerous substances in the form of gas, vapor or mist is likely to occur in normal operation occasionally.
- Zone 2: A place in which an explosive atmosphere consisting of a mixture with air of dangerous substances in the form of gas, vapor or mist is not likely to occur in normal operation but, if it does occur, will persist for a short period only.
- Zone 20: A place in which an explosive atmosphere in the form of a cloud of combustible dust in air is present continuously, or for long periods or frequently.
- Zone 21: A place in which an explosive atmosphere in the form of a cloud of combustible dust in air is likely to occur in normal operation occasionally.
- Zone 22: A place in which an explosive atmosphere in the form or a cloud of combustible dust in air is not likely to occur in normal operation but, if it does occur, will persist for a short period only.

Reduce Your Material Lost.

Avoid the Risk of Legal Fine

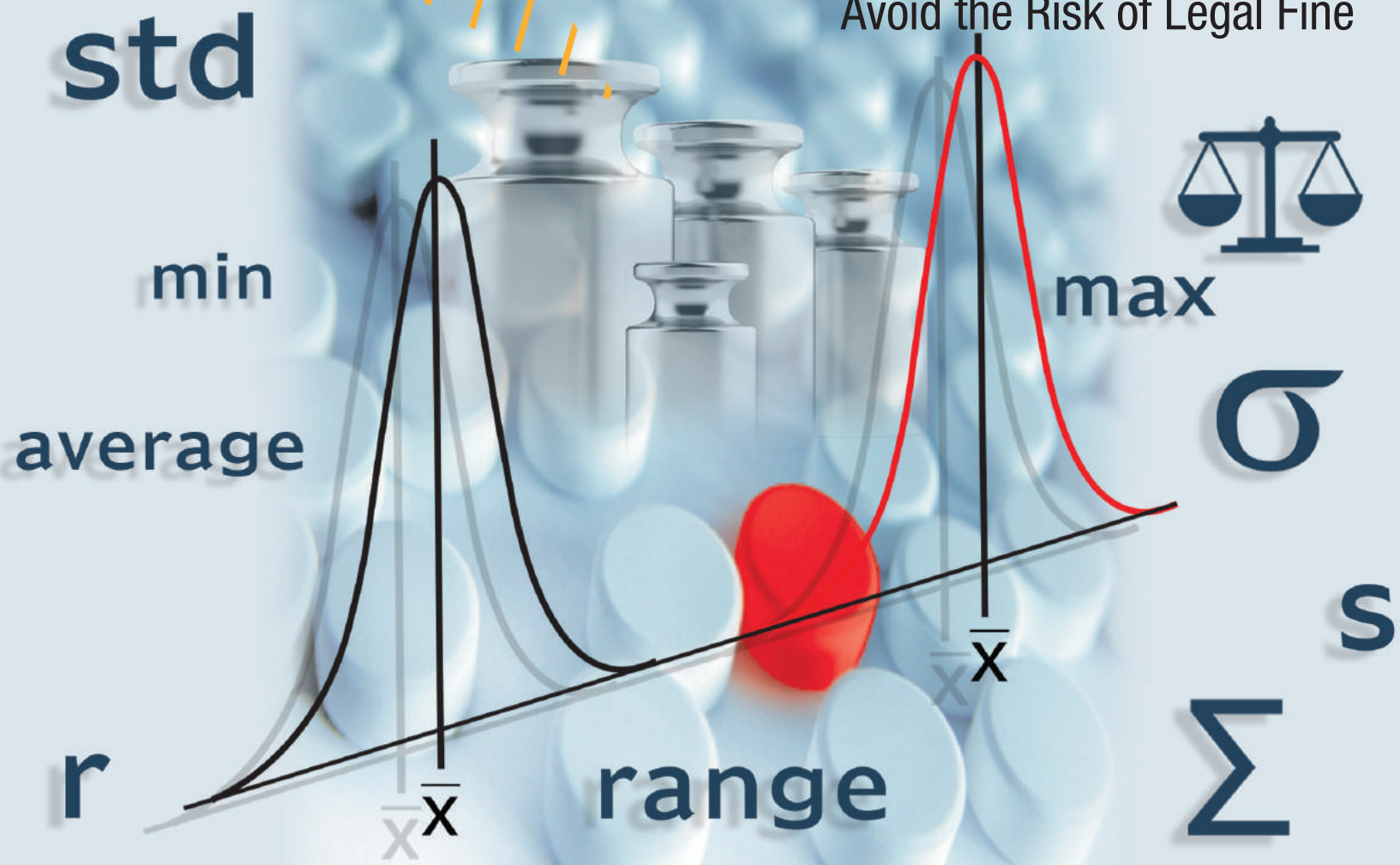

**BAYKON SQC<sup>®</sup>**  
**Statistical Quality Control**

# What is SQC?

Filling quantities of packaged food, beverages, cosmetics and chemicals are subject to strict regulations. According to these regulations, the filling quantities must not be below the defined minimum value. Weight and volume quantity below the limits can result not only in the reputation of the manufacturer, but also legal penalties. It is also in the producer's interest not to overfill the packs, as overfilling means waste of product. Statistical Quality Control (SQC) is used in production to ensure filling quantities stay within the required tolerance range and optimize quantities to maintain margins and profitability.

BAYKON SQC software:

- ✓ Provides reliable net content control of your products during filling and packing processes
- ✓ Automatically saves weighing records for traceability
- ✓ Helps you to fulfil legal requirements
- ✓ Produce statistical reports including average weight, standard deviation
- ✓ Guides operators in setting up filling machines to prevent over or underfillings.
- ✓ Creates records to analyse filling performance of your machines

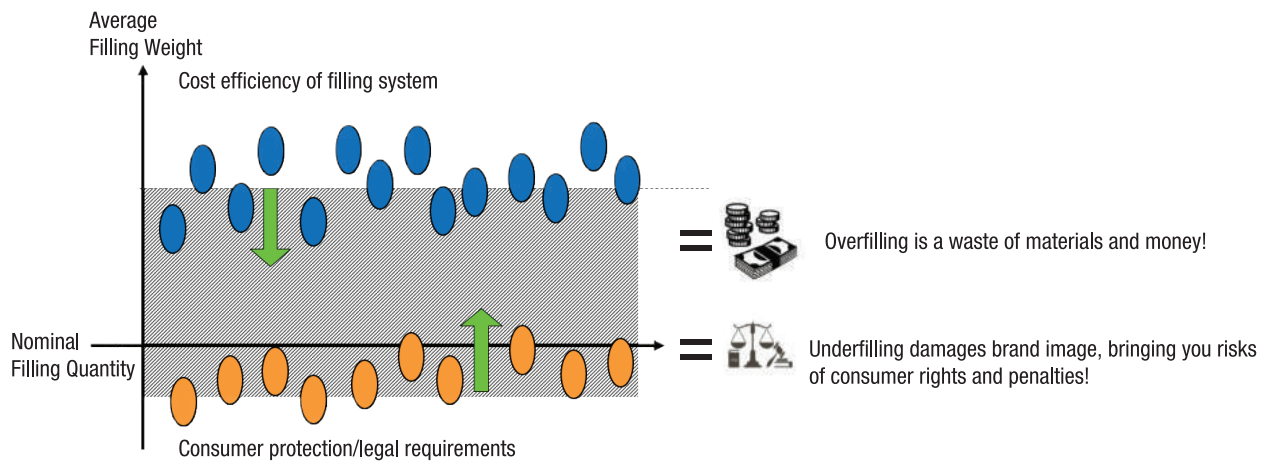

## What is Net Weight Control?

Ensuring net weight tolerances of prepacked products according to European Directives 76/211/EEC - 75/107/EEC and other international and national standards. Monitoring of the overfilling and underfilling risks during production process and taking corrective measures.

Excess Filling Cost			
1 kg price of the material	20	USD	A
Package quantity produced in one day	5000	pieces	B
Nominal filling quantity	100	gr	C
Number of days in per year	250	days	D
The average value of the product filling	102	gr	E
Excess filling per package	2	gr	H = E - C
Excess filling per day	10	kg	I = B x H/1000
Excess filling per year	2500	kg	J = D x I
Cost of excess filling per year	50000	USD	K = A x J

# Why BAYKON SQC?

With the help of BAYKON SQC, you can fulfill legal requirements of e-marking directives, prevent your risks caused by over or underfilling. Controlling product lost will provide rapid payback. All weighing data is recorded and processed to get reports for legal audits, quality and cost calculations. BAYKON SQC software performs quality control functions, provides online production traceability and instant detailed reports such as quality, product statistics, alarms, and machines' performances, and enables filling operators to participate in the production process.

With the online Server connection feature, the weighing records are automatically recorded. Thus, you can improve your production process by taking instant reports and making statistical evaluations.

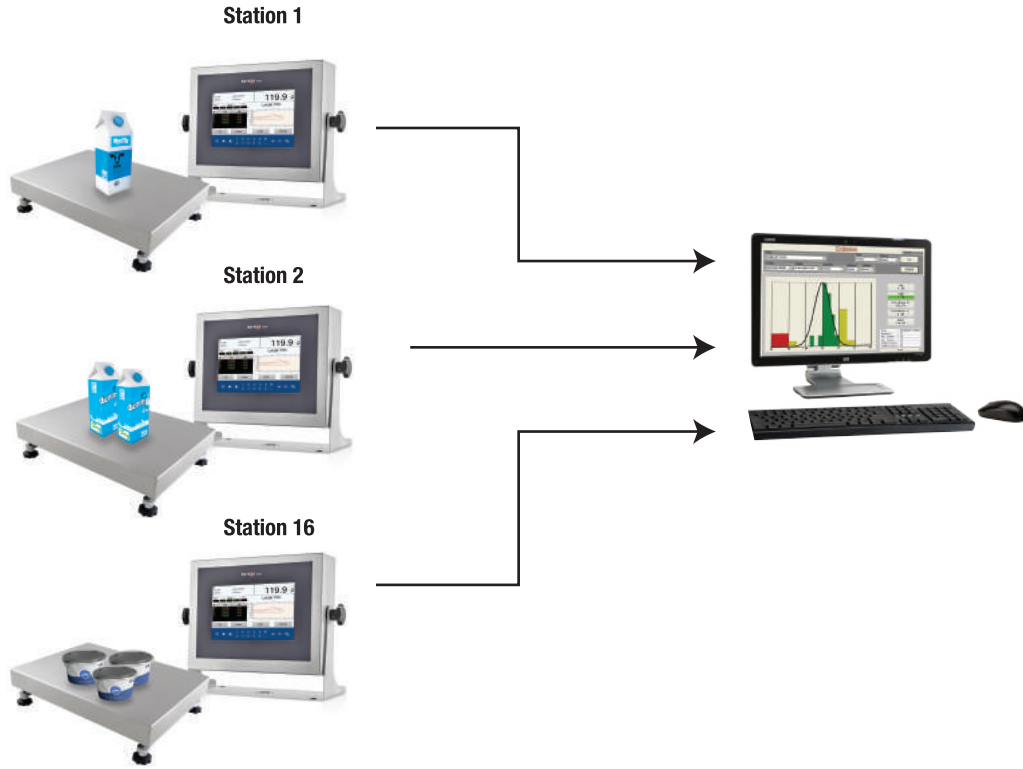

**Raporlar**

Kullanıcı: [Hepsi] Grup: [Hepsi] Parti: [Hepsi] Makine: [Hepsi] Liste: [Hepsi]  
 Başlangıç Tarihi: 01.06.2018 00:00 Bitiş Tarihi: 15.06.2018 23:59 Operatör: [Hepsi] İstasyon: [Hepsi] Varyasyon: [Hepsi] İstasyon: [Hepsi] Transfer Et

Numara	Ürün Adı	İstasyon	T2-	T1-	T1+	T2+	Ortalama Değer	Nominal	Parti
1	TURSU NO2	2	0	0	1	0	203.50	200.00	
2	TURSU NO2	1	0	0	0	0	201.70	200.00	
3	TURSU NO2	2	0	0	0	0	193.90	200.00	
4	TURSU NO1	2	0	0	0	0	400.00	400.00	
5	TURSU NO1	2	0	0	0	0	400.00	400.00	
6	TURSU NO2	1	0	0	0	0	199.90	200.00	
7	TURSU NO8	2	0	0	1	1	434.33	400.00	
8	TURSU NO8	2	0	0	0	1	500.00	400.00	
9	TURSU NO1	2	0	0	0	0	199.00	200.00	
10	TURSU NO2	2	0	0	0	0	199.90	200.00	
11	TURSU NO2	1	0	0	0	0	199.90	200.00	
12	TURSU NO2	2	0	0	0	1	206.50	200.00	
13	TURSU NO1	1	0	0	0	1	448900000.00	400.00	
14	TURSU NO8	1	0	0	0	1	3641500000.00	400.00	
Ortalama 0									
Minimum									
Maksimum									
Standart									
Genel									

**Alarmlar**

Kullanıcı: [Hepsi] Grup: [Hepsi] Parti: [Hepsi] Makine: [Hepsi] Liste: [Hepsi]  
 1. Tarih: 01.05.2018 00:00 2. Tarih: 15.07.2018 23:59 Operatör: [Hepsi] İstasyon: [Hepsi] Varyasyon: [Hepsi] Alarm Kodu: [Hepsi] Transfer Et

No	Tarih Saat	Ab	Kodu	Grup	Alarm	İstasyon	Operatör	Batch	Makine	Periyot
3	20.06.2018	FASULYE	KON003	KONSERVE	Varyasyon	1	BHAYIROGLU			2
4	20.06.2018	FASULYE	KON003	KONSERVE	Ortalama Parti1	1	BHAYIROGLU			2
5	20.06.2018	FASULYE	KON003	KONSERVE	Günlük	1	BHAYIROGLU			2
6	20.06.2018	FASULYE	KON003	KONSERVE	Varyasyon	1	BHAYIROGLU			2
7	20.06.2018	FASULYE	KON003	KONSERVE	Ortalama Parti1	1	BHAYIROGLU			2
8	20.06.2018	FASULYE	KON003	KONSERVE	Günlük	1	BHAYIROGLU			2
9	27.06.2018	MSIR	KON004	KONSERVE	Varyasyon	1	BHAYIROGLU			2
10	27.06.2018	MSIR	KON004	KONSERVE	Ortalama Parti1	1	BHAYIROGLU			2
11	27.06.2018	MSIR	KON004	KONSERVE	Günlük	1	BHAYIROGLU			2
12	20.06.2018	BEZELYE	KON001	KONSERVE	T2-Agama	1	BHAYIROGLU			2
13	20.06.2018	BEZELYE	KON001	KONSERVE	T2-Agama	1	BHAYIROGLU			2
14	20.06.2018	BEZELYE	KON001	KONSERVE	T2-Agama	1	BHAYIROGLU			2
15	20.06.2018	BEZELYE	KON001	KONSERVE	T2-Agama	1	BHAYIROGLU			2
16	20.06.2018	BEZELYE	KON001	KONSERVE	T2-Agama	1	BHAYIROGLU			2
17	20.06.2018	BEZELYE	KON001	KONSERVE	T2-Agama	1	BHAYIROGLU			2
18	20.06.2018	BEZELYE	KON001	KONSERVE	T2-Agama	1	BHAYIROGLU			2
19	20.06.2018	BEZELYE	KON001	KONSERVE	T1-Agama	1	BHAYIROGLU			2
20	20.06.2018	BEZELYE	KON001	KONSERVE	T2-Agama	1	BHAYIROGLU			2
21	20.06.2018	MSIR	KON004	KONSERVE	T1-Agama	1	BHAYIROGLU			2
22	13.06.2018	TURSU NO1	TR0001	TURSU	T1-Agama	2	BHAYIROGLU			2
23	13.06.2018	TURSU NO2	TR0002	TURSU	T2-Agama	2	BHAYIROGLU			2
24	13.06.2018	TURSU NO2	TR0002	TURSU	Ortalama Parti1	2	BHAYIROGLU			2
25	13.06.2018	TURSU NO2	TR0002	TURSU	T2-Agama	2	BHAYIROGLU			2

## Validation

Baykon SQC is validated according to international standards by experienced Baykon service team to ensure that results are accurate, valid and reliable.

# Fully controlled and traceable production with continuous data flow

Thanks to the instant data collected continuously during production, an opportunity for each level of operation and management, such as operators, production managers, quality managers, maintenance managers, and senior management, to participate in production, raise awareness, and improve production continuously.

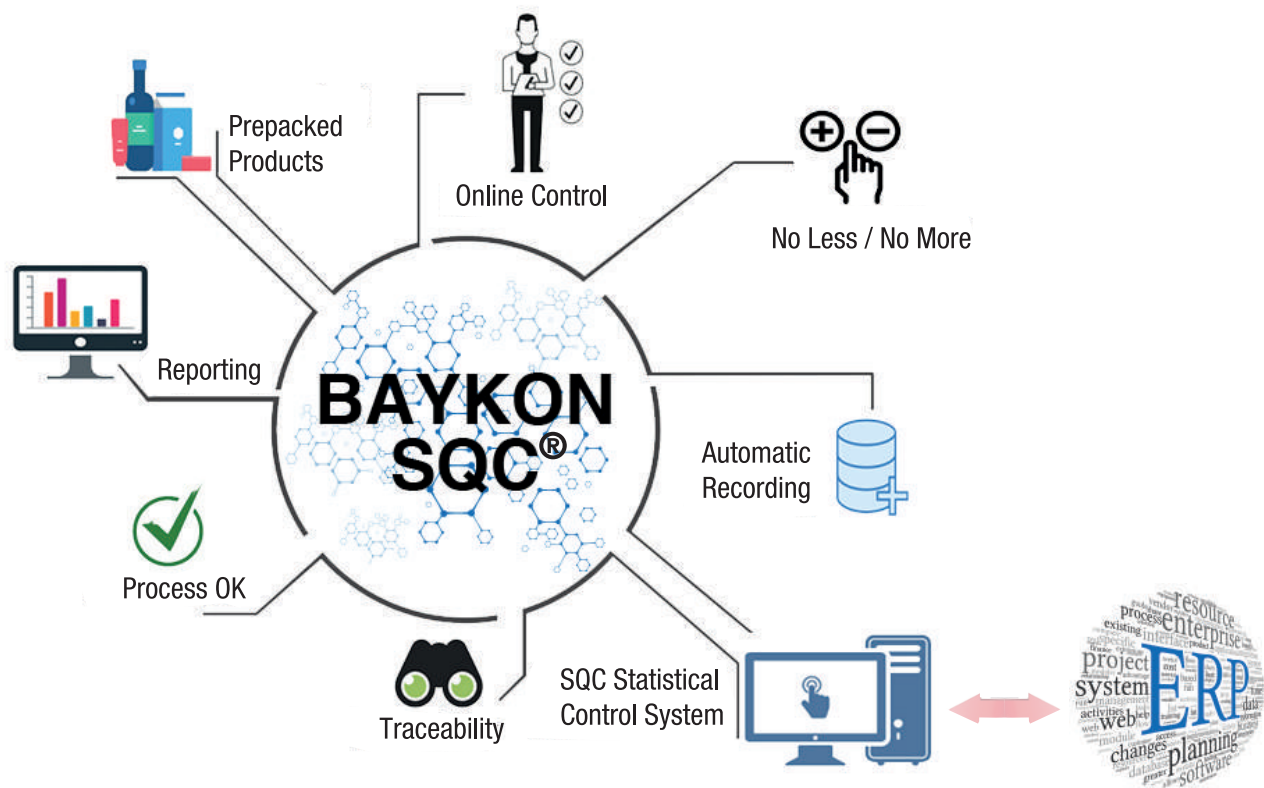

## With the BAYKON SQC System;

- ✓ **Filling Operators**, performing the sampling task actively, participate in the production process by being guided by BAYKON SQC according to the sampling result.
- ✓ **Production**, thanks to the easy-to-monitor screen of BAYKON SQC, can follow every process related to production instantly and without errors.
- ✓ **Quality assurance**, with the BAYKON SQC, monitors and documents quality systems and standards, such as ISO, SPC, or GMP. Compliance with quality regulations will be extremely easy as you have permanent control over weight, quality characteristics and other variables.
- ✓ **Maintenance** based on the statistical filling results, evaluates the performance of the filling machines continuously, makes preventive maintenance planning to ensure the production lines work with maximum efficiency.
- ✓ **The Management** is happy to have a production process that is under control, that meets legal obligations, that is recorded, that can be analyzed for future developments, that can be monitored, and that is efficient.





# Industrial Scales for Your Needs

Bench, Floor, Mobile and Easy Clean



## Industrial Scales

# Bench / Portable Scales

## BT Series Bench and Stand Scales

- Different capacities from 3 kg to 600 kg
- Measures up to 80 x 90 cm starting from 24 x 30 cm
- High precision starting from 0.5 gr, OIML approval
- According to process requirements in the field, the indicator and platform modular selection between models
- Static painted depending on working environment, stainless steel cap, galvanized or complex stainless steel
- Functions such as simple weighing, dynamic weighing, labeling, filling, control and grading, part counting, memory weighing
- Special optional features.



### Professional Design

Baykon BT series scales are designed to international standards for years to serve you.

### Advanced Electronic Technology

High quality OIML class load cells with equipment structure Baykon's combination with weighing indicators manufactured using advanced electronic technology to provide very high weighing accuracy compared to ordinary scales.

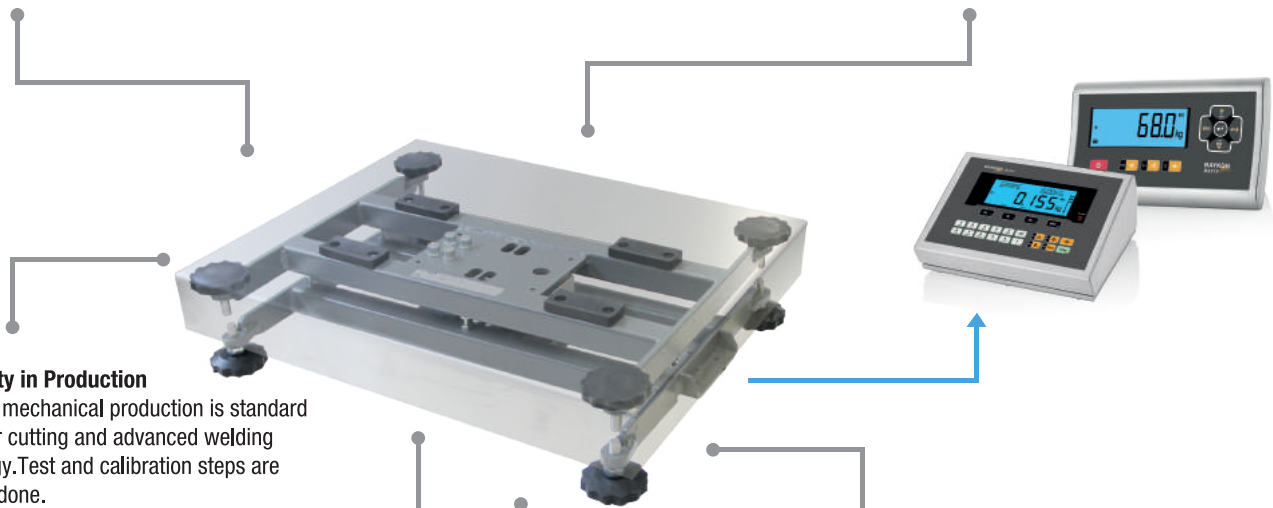

### Sensitivity in Production

Precision mechanical production is standard with laser cutting and advanced welding technology. Test and calibration steps are carefully done.

### Conformity to Hygienic Conditions

For wet and washable industrial fields, IP67, IP68 and even IP69 protection class waterproof models are equipped with maximum precision and safe weighing.

### Powerful Options

There are some options such as; indicator pole, visor, wheeled carrying stand, mechanics such as idle roller assembly and printer, external display, software electronic options.

### Functionality

BT series scales provide ergonomic usage both with various capacity and sized weighing platforms and with their modular structure.



# Floor Scales

## BK Series Floor Scales

- At capacities from 300 kg to 15000 kg
- Sensitivities starting from 50 g
- From 100 x100 cm up to 3000 x 3000 cm platform dimensions
- Ground or floor usage
- Fully compatible with demanding tough conditions
- Effective use with low profile
- Painted or stainless steel construction options
- OIML approval for commercial usage
- Standard IP67 load cells
- Functional features such as labeling, formulation, recipe preparation, part counting, filling, dynamic weighing, control weighing and grading.

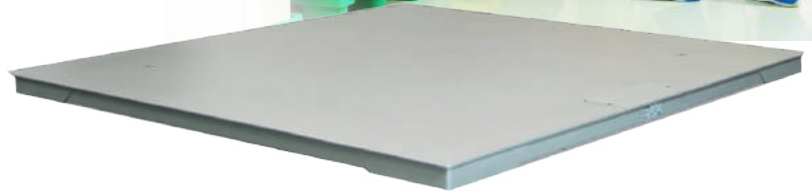

## BL Floor Scales

- 300 kg / 600 kg / 1500 kg
- Sensitivities starting from 50 g,
- From 85 x85 cm up to 150 x 150 cm platform dimensions,
- Ergonomic using with ground and 45mm low platform height,
- For effective cleaning in wet and hygienic areas lifting mechanism supported by hydraulic pistons,
- Standard stainless steel and IP68 waterproof construction,
- Fully compatible with GMP and HACCP production standards,
- OIML approval for commercial use,
- Functional features such as labeling, formulation, recipe preparation, part counting, filling.



## BP Floor Scales

- 300 kg / 600 kg / 1500 kg / 3000 kg,
- Sensitivities starting from 50 g,
- 100 x 100, 120 x 150 or 150 x 150 cm,
- On-ground or indoor use,
- Plunging platform cover with piston support for effective cleaning and ergonomic use in wet and hygienic areas,
- Standard stainless steel and IP68 waterproof structure optional SS316,
- Fully compatible with GMP and HACCP production standards,
- OIML approval for commercial use,
- Functional features such as labeling, formulation, prescription, parts counting, filling.



# Special Constructions

## BU Pallet Scale

- 1500 kg and 3000 kg
- Sensitivities starting from 200 g
- Designed for weighing pallet loads
- 25 x 85 cm in dimensions, 85 mm in height
- Mobile and ergonomic usage
- Standard IP65 painted steel and optional IP68 stainless steel
- OIML approval for commercial use
- Advanced functional features such as, simple weighing, labeling, part counting, filling

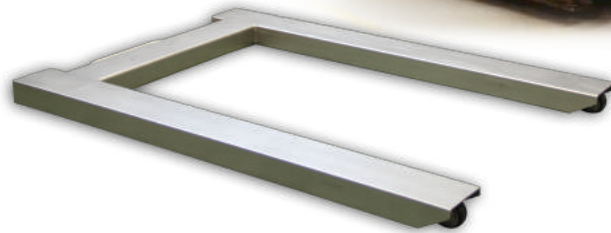

Replacing your existing forks with our high quality MagicFORKS adds Weighing, Labelling and Data Management functions to your forklift. A complete wireless design enables quick and easy installation in minutes and transportability from one forklift to other.

Powerful Li-Ion battery packs provide up to 65 hours continuous operation. Efficient power management supported by automatic sleep mode and battery shutdown ensures weeks of operation between charges.



Baykon TB Pallet Truck Scale has robust industrial structure suitable for mobile use. Painted and stainless steel models are available up to a maximum capacity of 2000 kg. It provides long-term and trouble-free operation with a long-lasting battery supported by rechargeable sleep mode.









## Innovative Weighing Technologies

World-class weighing products & solutions...

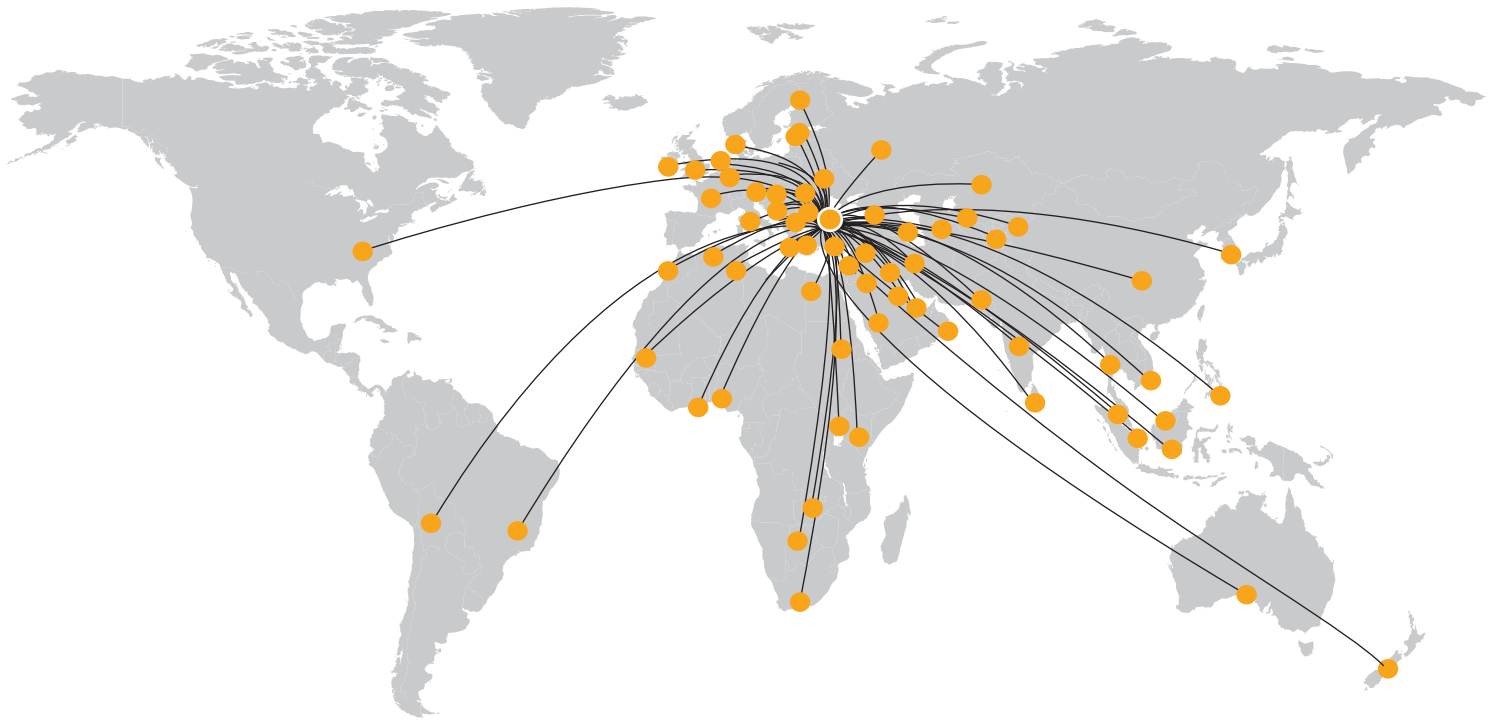

*Specifications are subject to change without notice. 03 - 03 / 2024)*

**Head Office | İstanbul**  
✉ info@baykon.com  
☎ +90 216 593 26 30

**Offices | İzmir**  
✉ ege@baykon.com  
☎ +90 232 469 97 91

**Germany**  
✉ kontakt.de@baykon.com

**BAYKON**  
Industrial Weighing Systems